

## Features

- Complete Touchscreen Module:
  - Projected Capacitive Multi Touch Controller
  - 4.3in LCD
  - 4 Capacitive “Navigation” Keys
  - 200 bytes non-volatile serial EEPROM
- Touch:
  - Atmel maXTouch™ mXT336T Touch Controller
  - Supports up to 10 touches
- Display:
  - 480x272 resolution
  - Himax HX8257-A driver IC
  - 30 ms response time
  - White LED backlight
- Navigation Keys:
  - Atmel AT42QT1070 QTouch™ Button Sensor IC
- Cover Panel:
  - 2mm Soda Lime



## PDA TM4301B: 4.3in PCAP Touch Module

P/N: 90-00123-A0



Visit <http://www.pdaatl.com/tm4301b>  
for the latest information on the TM4301B

Doc: 111-00221-A0



## Contents

1	Module Overview	4
1.1	PCB Connections	4
1.2	Host Interface J1	5
1.3	Touch Interface Connector J2	6
1.4	Module Interface Connector S-J1	6
1.5	Nav Button Connector J3 & J4	7
1.6	Display Flex Connector J5	8
1.7	Touch Sensor Flex Connector S-J2	9
2	Overview of the 4.3in PCAP Touch Module	10
2.1	Introduction	10
2.2	Understanding Unfamiliar Concepts	11
2.3	LCD Panel	11
2.4	maXTouch Capacitive Touchscreen Controller	11
2.4.1	maXTouch Controller Interface	11
2.5	QTouch Capacitive Button Controller	12
2.5.1	QTouch Controller Interface	12
2.6	Serial EEPROM	12
3	Getting Started	13
3.1	Hardware Connections	13
3.2	Software	13
3.3	Using the Touch Module	13
3.3.1	Navigation Keys	13
3.3.2	Evaluating the Touch Module	14
4	Specifications	15
4.1	Mechanical Specifications	15
4.2	Absolute Maximum Specifications	17
4.3	Recommended Operating Conditions	17
4.4	DC Specifications	17
4.5	I2C-compatible Bus Specifications	18
4.6	LCM Specification	18
4.6.1	LCM Parameters	18
4.6.2	LCM Absolute Maximum Specifications	19
4.6.3	LCM DC Specifications	19
4.6.4	LCM Optical Characteristics	19
4.7	Power Consumption	20

4.8	Part Number	20
5	I2C Basics (I2C-compatible Operation)	21
5.1	Interface Bus	21
5.2	Transferring Data Bits	21
5.3	START and STOP Conditions	21
5.4	Address Byte Format	22
5.5	Data Byte Format	22
5.6	Combining Address and Data Bytes into a Transmission	23
6	Revision History	24
7	Notes	25

# 1 Module Overview

## 1.1 PCB Connections

The TM4301B is composed two PCBs: a Module PCB (10-01111-A0) and a Sensor PCB (10-01093-B0). The reference designators shown below for various connectors will use an “S” prefix when the connector is located on the sensor PCB (for example “S-J1”). Reference designators without a prefix are located on the Module PCB.

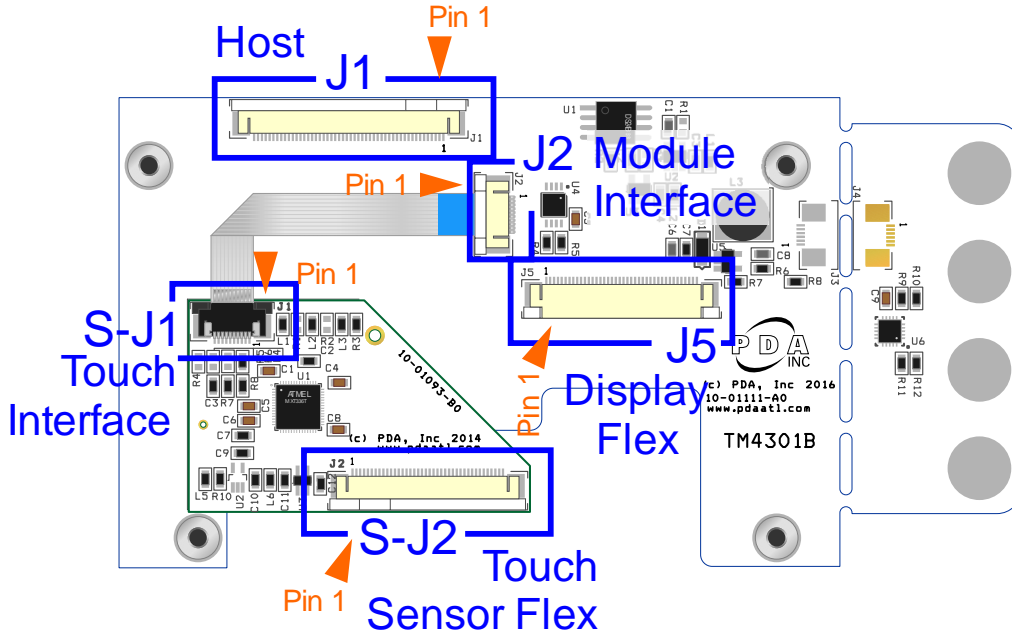

**Figure 1 - PCB Connectors**

NOTE: Insert flex in Connector J6 with contacts facing DOWN.

The following notations are used for pin descriptions:

I	Input only	OD	Open drain output
O	Output only, push-pull	P	Ground or power
MXT	maXTouch touchscreen	QT	QTouch Button Controller
EE	Serial EEPROM	LCD	LCD Panel

NOTE: Except where noted otherwise, inputs and output are defined from the standpoint of the Touch Module PCB.

## 1.2 Host Interface J1

Connector J1 implements Atmel's "XPRO LCD" connector found on various Xplained and Xplained Pro evaluation kits.

Connector J1 connects to the host provides interface between the host and (1) the MaXTouch Touch Controller, (2) the QTouch Button Controller, (3) LCD Panel, and (4) serial EEPROM.

Suggested Flex:

Wurth Electronics #687 650 100 002,

Description: 0.5mm pitch 50 position FFC, Length 100mm

Flex should be inserted with contacts **facing DOWN**.

Pin	Type	Description	MX	LT	QT	EE
1	I/O	One-Wire Interface				•
2	P	GND				
3	I	LCD_DATA_0		•		
4	I	LCD_DATA_1		•		
5	I	LCD_DATA_2		•		
6	I	LCD_DATA_3		•		
7	P	GND				
8	I	LCD_DATA_4		•		
9	I	LCD_DATA_5		•		
10	I	LCD_DATA_6		•		
11	I	LCD_DATA_7		•		
12	P	GND				
13	I	LCD_DATA_8		•		
14	I	LCD_DATA_9		•		
15	I	LCD_DATA_10		•		
16	I	LCD_DATA_11		•		
17	P	GND				
18	I	LCD_DATA_12		•		
19	I	LCD_DATA_13		•		
20	I	LCD_DATA_14		•		
21	I	LCD_DATA_15		•		
22	P	GND				
23	I	LCD_DATA_16		•		
24	I	LCD_DATA_17		•		
25	I	LCD_DATA_18		•		

Pin	Type	Description	MX	LT	QT	EE
26	I	LCD_DATA_19		•		
27	P	GND				
28	I	LCD_DATA_20		•		
29	I	LCD_DATA_21		•		
30	I	LCD_DATA_22		•		
31	I	LCD_DATA_23		•		
32	P	GND				
33	I	PCLK		•		
34	I	VSYNC		•		
35	I	HSYNC		•		
36	I	DE		•		
37	-	N/C				
38	-	N/C				
39	-	N/C				
40	-	N/C				
41	I	DISP		•		
42	I	I <sup>2</sup> C SDA	•		•	
43	I/O	I <sup>2</sup> C SCL	•		•	
44	O	~MXT_CHG	•			
45	O	~QT_CHG			•	
46	I	LCD_PWM		•		
47	I	~RESET	•		•	
48	P	+5Vdc				
49	P	+5Vdc				
50	P	GND				

### 1.3 Touch Interface Connector J2

Connector J2 connects to the Sensor PCB and carries signals between the host and the MaXTouch Touch Controller.

Flex should be inserted with contacts **facing DOWN**.

Pin	Type	Description
1	O	I <sup>2</sup> C SCL
2	I/O	I <sup>2</sup> C SDA
3	O	~MXT_RESET
4	I	~MXT_CHG
5	P	V <sub>DD</sub>

Pin	Type	Description
5	P	GND
5	P	AV <sub>DD</sub>
8	-	N/C
9	-	N/C
10	P	GND

### 1.4 Module Interface Connector S-J1

Connector J1 *located on the Sensor PCB* connects to the Module PCB and carries signals between the MaXTouch Touch Controller and the host

NOTE: Inputs and output are defined from the standpoint of the Sensor PCB.

Flex should be inserted with contacts **facing UP**.

Pin	Type	Description
1	O	I <sup>2</sup> C SCL
2	I/O	I <sup>2</sup> C SDA
3	O	~MXT_RESET
4	I	~MXT_CHG
5	P	V <sub>DD</sub>

Pin	Type	Description
5	P	GND
5	P	AV <sub>DD</sub>
8	-	N/C
9	-	N/C
10	P	GND

## 1.5 Navigation Button Connector J3 & J4

Optionally connects to the Navigation Button PCB and carries signals between the host and the QTouch Controller used to detect input on the Nav buttons.

While navigation buttons can be used in place, the module PCB was designed to allow removal and optional 'remote' use of the buttons. The button PCB can be separated by carefully cutting the PCB along the scoring, ensuring cut traces (top and bottom) are not shorted. Populate connectors J3 (on the module PCB) and J4 (on the Nav button PCB) and connect using a flex cable.

Suggested Connector:

TE 1734839-6

Suggested Flex:

Würth Electronics #687 606 LLL 002,

Description: 0.5mm pitch 6 position FFC, Length *LLL*mm

Flex should be inserted with contacts **facing DOWN**.

J3 Pin	J3 Type	Description	J4 Pin	J4 Type
1	P	V <sub>DD</sub>	6	P
2	O	~QT_RESET	5	I
3	I	~QT_CHG	4	O
4	O	I <sup>2</sup> C SCL	3	I
5	I/O	I <sup>2</sup> C SDA	2	I/O
6	P	GND	1	P

## 1.6 Display Flex Connector J5

Connector J5 connects to the LCD panel flex and carries signals between the host and the LCD Panel.

NOTE: Pin 1 on the Module PCB aligns to pin 40 on the LCM flex.

Flex should be inserted with contacts **facing UP**.

Pin	Type	Description
1	-	N/C
2	-	N/C
3	-	N/C
4	-	N/C
5	P	GND
6	-	N/C
7	O	DE
8	O	VSYNC
9	O	HSYNC
10	O	DISP
11	O	PCLK
12	P	GND
13	O	LCD_DATA_7 / B7
14	O	LCD_DATA_6 / B6
15	O	LCD_DATA_5 / B5
16	O	LCD_DATA_4 / B4
17	O	LCD_DATA_3 / B3
18	O	LCD_DATA_2 / B2
19	O	LCD_DATA_1 / B1
20	O	LCD_DATA_0 / B0

Pin	Type	Description
21	O	LCD_DATA_15 / G7
22	O	LCD_DATA_14 / G6
23	O	LCD_DATA_13 / G5
24	O	LCD_DATA_12 / G4
25	O	LCD_DATA_11 / G3
26	O	LCD_DATA_10 / G2
27	O	LCD_DATA_9 / G1
28	O	LCD_DATA_8 / G0
29	O	LCD_DATA_23 / R7
30	O	LCD_DATA_22 / R6
31	O	LCD_DATA_21 / R5
32	O	LCD_DATA_20 / R4
33	O	LCD_DATA_19 / R3
34	O	LCD_DATA_18 / R2
35	O	LCD_DATA_17 / R1
36	O	LCD_DATA_16 / R0
37	P	+3.3Vdc
38	P	GND
39	P	LED+
40	P	LED-



## 1.7 Touch Sensor Flex Connector S-J2

Connector S-J2 connects to the touch sensor flex and carries signals used by the maXTouch controller to detect input on the touch sensor.

Pin	Type	Description
1	P	GND
15	I/O	X23
14	I/O	X22
13	I/O	X21
12	I/O	X20
11	I/O	X19
10	I/O	X18
9	I/O	X17
8	I/O	X16
7	I/O	X15
6	I/O	X14
5	I/O	X13
4	I/O	X12
3	I/O	X11
2	I/O	X10
16	I/O	X9
17	I/O	X8
18	I/O	X7
19	I/O	X6
20	I/O	X5

Pin	Type	Description
21	I/O	X4
35	I/O	X3
34	I/O	X2
33	I/O	X1
32	I/O	X0
31	I/O	S0
30	I/O	Y0
29	I/O	Y1
28	I/O	Y2
27	I/O	Y3
26	I/O	Y4
25	I/O	Y5
24	I/O	Y6
23	I/O	Y7
22	I/O	Y8
36	I/O	Y9
37	I/O	Y10
38	I/O	Y11
39	I/O	Y12
40	I/O	Y13

## 2 Overview of the 4.3in PCAP Touch Module

### 2.1 Introduction

The 4.3in PCAP Touch Module is a touchscreen module offering best-in-class projected capacitance multi-touch functionality combined with a 4.3in LCD panel. The module is configured for development and evaluation with several Atmel ARM-based evaluation solutions as well as development and integration with a custom host system.

For convenience, this module features Atmel's "Xplained Pro LCD" connector ([J1](#)) for use with Xplained and Xplained Pro/Ultra evaluation hardware.

As shown in Figure 2 below, several sub-system components are accessible to maximize effective integration.

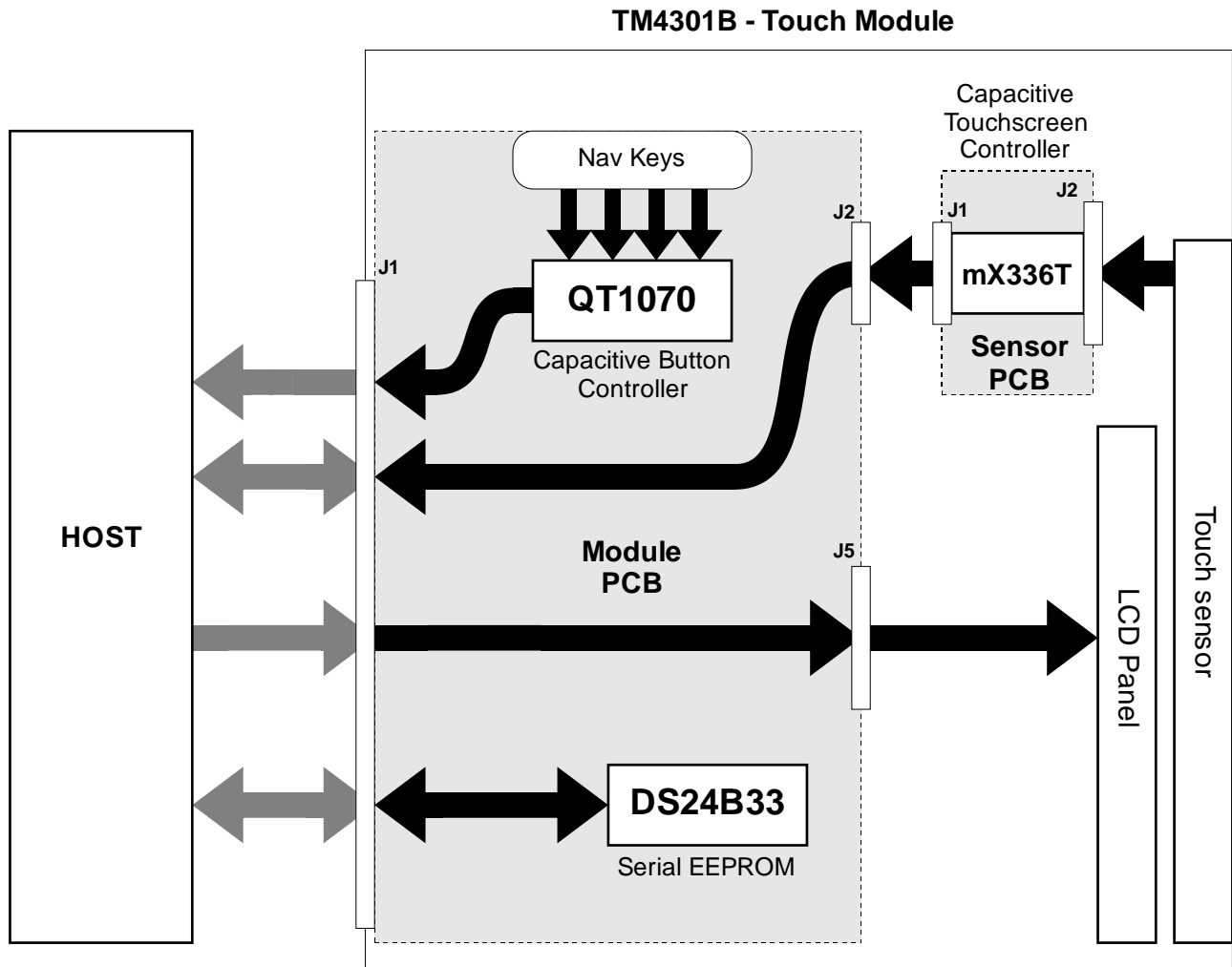

Figure 2 - Functional Block Diagram

## 2.2 Understanding Unfamiliar Concepts

Throughout this document, the functionality of the module sub-system will be outlined and summarized. However, the user is encouraged to refer to the resources and documents below in order to gain a more thorough understanding of each sub-system.

- For a basic overview of I<sup>2</sup>C communication, refer to [Section 5](#) of this document
- Atmel maXTouch mXT336T ([www.atmel.com](http://www.atmel.com))
- Atmel QTouch QT1070 Datasheet ([www.atmel.com](http://www.atmel.com))
- Maxim DS24B33 Datasheet ([www.maximintegrated.com](http://www.maximintegrated.com))

In addition, when developing or evaluating with the Atmel ARM-based EK's, it is recommended that the user visit [www.at91.com](http://www.at91.com) which contains a broad range of resources for the EK's and the ARM devices they feature.

## 2.3 LCD Panel

The module provides the host with a direct connection ([Connector J1](#)) to the LCD panel interface ([Connector J5](#)). Aside from generating supply voltages for the LED backlight and providing backlight control to the host, no display panel control is performed by the module.

## 2.4 maXTouch Capacitive Touchscreen Controller

The module touch screen interface is based on the Atmel maXTouch mXT336T Touch Controller and operates using the touch sensor at [Connector S-J2](#).

The touch controller scans the touch sensor and will signal the host with an active low interrupt signal (~MXT\_CHG on [Connector J1](#)) when new touch data is available. Data communication with the maXTouch controller is performed over a shared I<sup>2</sup>C interface (I<sup>2</sup>C SCL and I<sup>2</sup>C SDA on [J1](#)). The I<sup>2</sup>C address of the touch controller is 0x4A.

**NOTE: The TM4301B has pull-up resistors on the maXTouch ~CHG\_mxt interrupt signal located at R8 on the sensor PCB. There are no external pull-ups on the I<sup>2</sup>C SCL and I<sup>2</sup>C SDA signals – the host must provide pull-up for these signals.**

### 2.4.1 maXTouch Controller Interface

Details of the maXTouch communication protocol are beyond the scope of this document. However information is provided in Section 3.2 below to facilitate evaluation and initial development.



**This module is pre-loaded with a configuration already optimized for this touch sensor and panel, so the developer need only focus on interfacing with the device. When developing the maXTouch controller interface during evaluation and host development, care should be taken to avoid changing the maXTouch configuration or committing changes to NV storage on the maXTouch controller.**

To get started with host interface development, the user is *strongly* encouraged to leverage existing code available from the resources outlined in Sections 3.2.

## 2.5 QTouch Capacitive Button Controller

The module's "nav key" interface is based on the Atmel QT1070 7-Channel Capacitive Sensor Driver.

The button controller scans the 4 capacitive nav keys (K1, K2, K3 and K4) and will signal the host with an active low interrupt signal (~QT\_CHG on [Connector J1](#)) when a touch event has occurred. Data communication with the QT1070 controller is performed over a shared I<sup>2</sup>C interface (I<sup>2</sup>C SCL and I<sup>2</sup>C SDA on [J1](#)). The I<sup>2</sup>C address of the button controller is 0x1B and cannot be changed.

**NOTE: The TM4301B has pull-up resistors on the QTouch ~CHG interrupt signal located at R8. There are no external pull-ups on the I<sup>2</sup>C SCL and I<sup>2</sup>C SDA signals – the host must provide pull-up for these signals.**

### 2.5.1 QTouch Controller Interface

Details of the QTouch communication protocol are beyond the scope of this document. The user is encouraged to review the QT1070 Datasheet ([www.atmel.com](http://www.atmel.com)).

## 2.6 Serial EEPROM

The module includes a DS24B33 Serial EEPROM providing 512 bytes of non-volatile storage. Data communication with the EEPROM is performed over a One-Wire Interface. The EEPROM is not used by another subsystem on the touch module and can be freely used by the host system for any purpose. For example, Atmel ARM-based EK's running Linux or Android operating systems use the pre-programmed contents of the EEPROM to identify this module type.



**NOTE: The user should take care if choosing to overwrite the pre-programmed EEPROM contents. As noted above, certain builds of Linux or Android provided by Atmel and targeted for the Atmel ARM-based EKs use the EEPROM contents to identify the module and may no longer recognize the module. The user is advised to back up the EEPROM contents before overwriting.**

The serial EEPROM communicates via a one-wire interface ("One-Wire Interface" on [J5](#) or [J6](#)). Refer to the DS24B33 Datasheet ([www.maximintegrated.com](http://www.maximintegrated.com)) for details.

## 3 Getting Started

This module was designed to install on a variety of Atmel ARM-based EK's including the SAMA5D3 Xplained, SAMA5D4 Xplained Ultra, SAMA5D2 Xplained Ultra and the SAMV71 Xplained Ultra among others. With prebuilt Linux and/or Android images available for many of these evaluation platforms, this provides the fastest way to evaluate the performance of the touchscreen and display using a familiar, full-featured OS.

The following sections provide basic information related to using and evaluating the Touch Module. Visit Precision Design Associates website ( [www.pdaatl.com](http://www.pdaatl.com) ) or Atmel's AT91 Community website ( [www.at91.com](http://www.at91.com) ) for more information related to this touch module or guidance appropriate for your specific EK.

### 3.1 Hardware Connections

The module interfaces with the evaluation board via the flex connector, [J1](#) (typically found on Xplained or Xplained Ultra kits). Refer to the specific EK documentation for more information.

### 3.2 Software

Several options exist when developing for the touch module whether targeting a custom host or an Atmel EK.

#### 3.2.1.1 Linux Kernel / Android

The Linux Kernel ([www.kernel.org](http://www.kernel.org)) has included basic support for maXTouch touch devices since version 2.6.36. The mainline driver has undergone considerable evolution since then.

Atmel hosts the AT91 community website with resources dedicated to developing on their EKs for Android ( [www.at91.com/android4sam/](http://www.at91.com/android4sam/) ) and Linux ( [www.at91.com/linux4sam/](http://www.at91.com/linux4sam/) )

Finally, Atmel maintains an up-to-date driver ([www.github.com/atmel-maxtouch/linux](http://www.github.com/atmel-maxtouch/linux)) which includes numerous out-of-cycle improvements to the mainline Linux Kernel maXTouch driver.

#### 3.2.1.2 Atmel Software Framework

The Atmel Software Framework ([asf.atmel.com](http://asf.atmel.com)) contains examples of code for interfacing with devices in the maXTouch family of touch controllers. The capabilities of various maXTouch devices may differ, but the basic communication protocol is common and can be applied to this module.

#### 3.2.1.3 Atmel Software Packages





Most of Atmel's Xplained kits have corresponding "Software packages" available with example projects which can be built using the Atmel Studio (and/or other) toolchains. Many of these software packages include examples directly supporting or written for the PDA TM43xx modules.

## 3.3 Using the Touch Module

### 3.3.1 Navigation Keys

When using this module with one of the standard Atmel Android demo builds, the navigation keys function as shown in Table 3-1 below:

**Table 3-1 - Navigation Key Function (Android)**

Key	Navigation Function
K1	 Back
K2	 Menu
K3	 Home
K4	 Power / Sleep

### 3.3.2 Evaluating the Touch Module

For effective evaluation of the module – the touch sensor and the LCD panel in particular – the user is encouraged to try the following applications and tools depending on the host OS.

#### 3.3.2.1 Android

The following Android apps available from Google Play:

[TouchTest](#) by Moonblink

[Doty](#) by Gerry Steele

[Multitouch Visible Test](#) by Battery Powered Games

[Screen Test](#) by Amberfog

#### 3.3.2.2 Linux

The user can perform simple touch / drawing test using the `ts_test` utility that is part of `tslib`.

## 4 Specifications

For complete specifications, refer to the datasheets listed in section 2.2 for the various sub-system components outlined in sections 2.3 through 2.6.

### 4.1 Mechanical Specifications

Contact PDA for drawings and CAD models available.

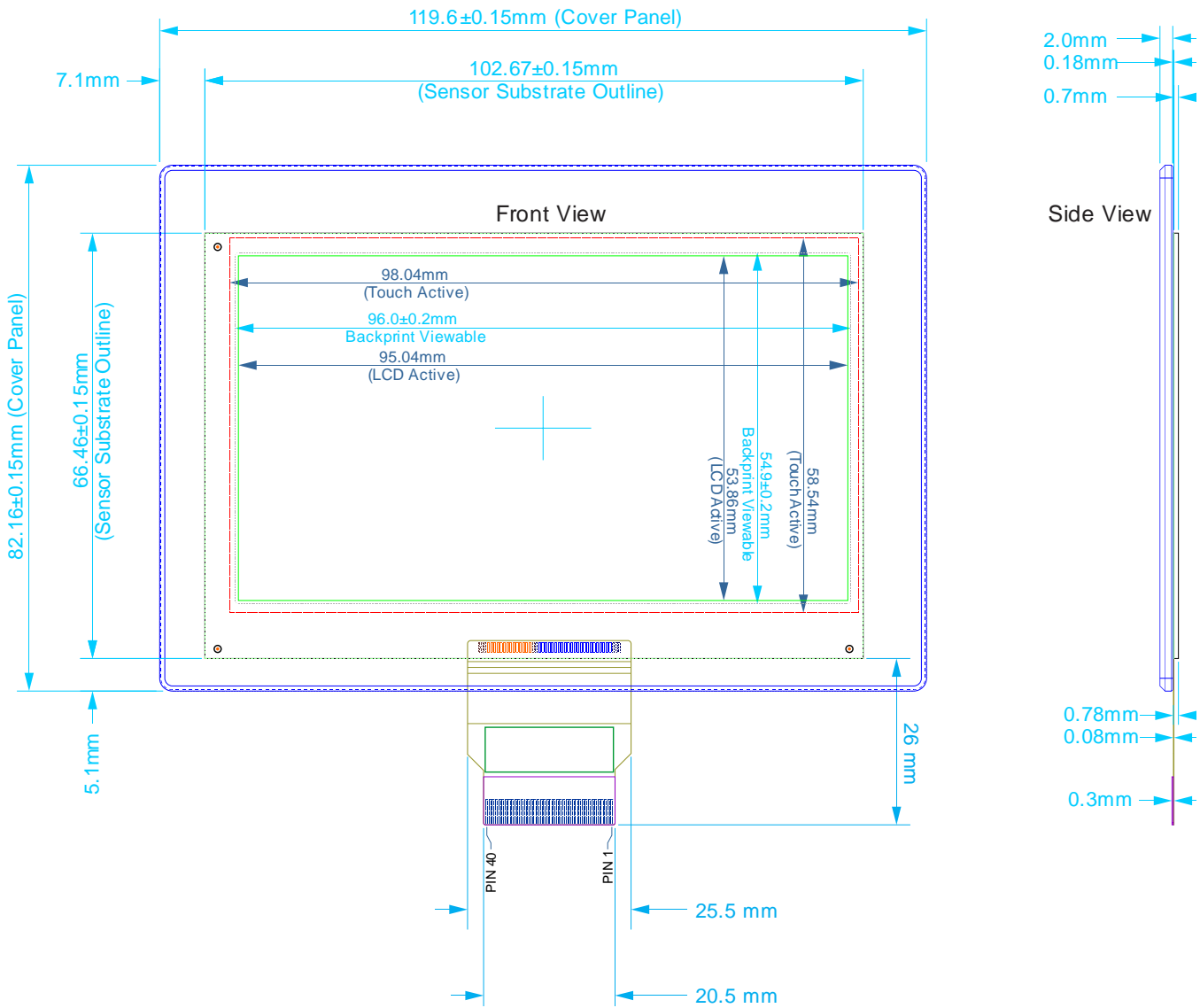

Sensor Assy (P/N: 90-00089-A0) may be purchased individually.  
 Minimum order quantities apply. Contact PDA for details.

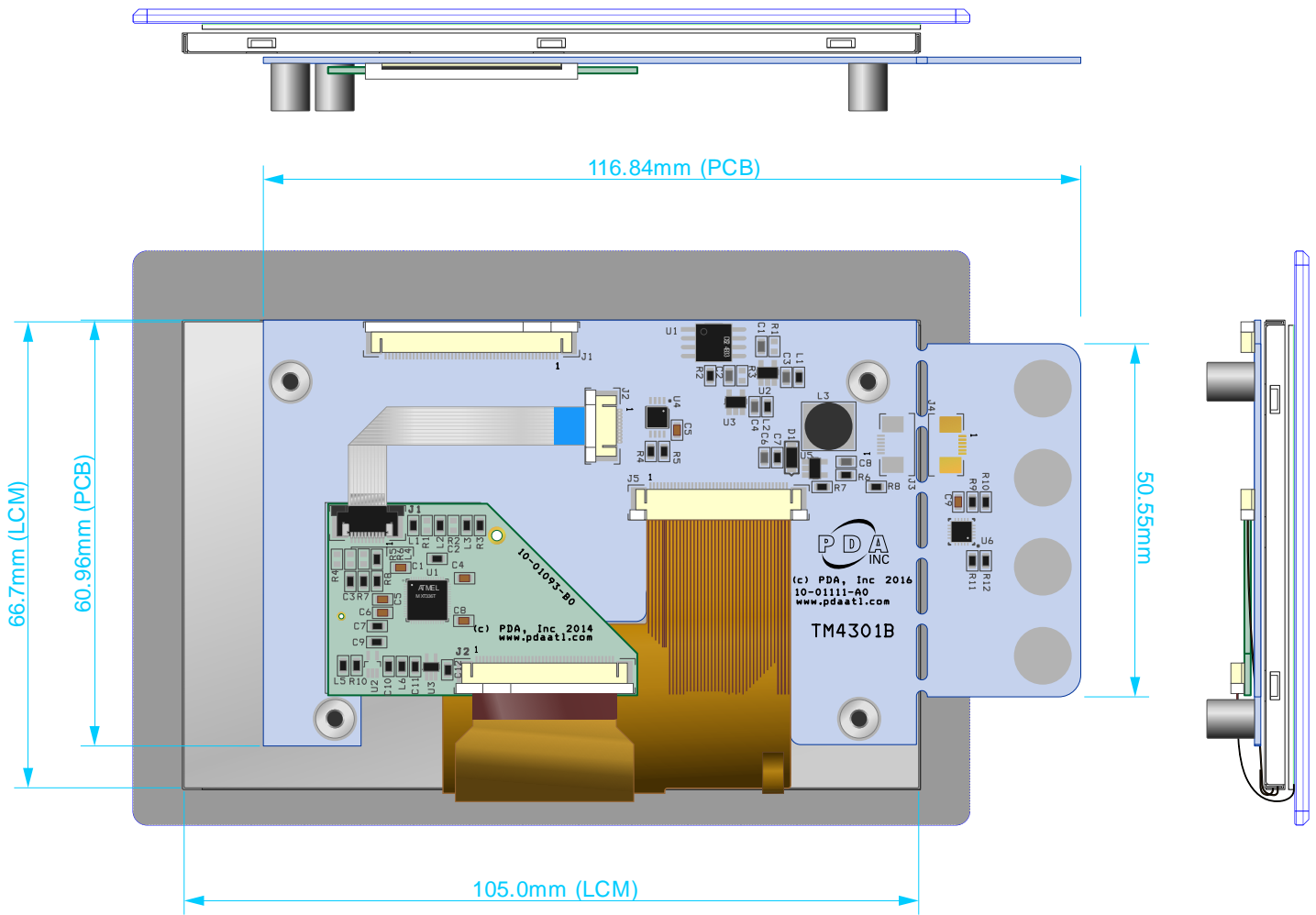

**Figure 4 – Module Dimensions**



## 4.2 Absolute Maximum Specifications

Parameter	Value
Operating temp	0°C to + 70°C
Storage temp	-40°C to + 85°C
Vdd	-0.5 to +6V
Max continuous pin current, any control or drive pin	±40 mA
Voltage forced onto any pin	-0.5V to (Vdd + 0.5) Volts
 <b>CAUTION:</b> Stresses beyond those listed under <i>Absolute Maximum Specifications</i> may cause permanent damage to the device. This is a stress rating only and functional operation of the device at these or other conditions beyond those indicated in the operational sections of this specification are not implied. Exposure to absolute maximum specification conditions for extended periods may affect device reliability.	

## 4.3 Recommended Operating Conditions

Parameter	Value
V <sub>in</sub>	5.0V ±5 percent
Supply ripple + noise	±20 mV

## 4.4 DC Specifications

V<sub>in</sub> = 5.0V, V<sub>dd</sub>=3.3Vdc, T<sub>a</sub> = recommended range, unless otherwise noted

Parameter	Description	Min	Typ	Max	Units	Notes
V <sub>IL</sub>	Low input logic level	- 0.5	–	0.3 V <sub>dd</sub>	V	1.8V <V <sub>dd</sub> <3.3V
V <sub>HL</sub>	High input logic level	0.7 V <sub>dd</sub>	–	V <sub>dd</sub> + 0.5	V	1.8V <V <sub>dd</sub> <3.3V
V <sub>OL</sub>	Low output voltage	–	–	0.2V <sub>dd</sub>	V	
V <sub>OH</sub>	High output voltage	0.8V <sub>dd</sub>	–	–	V	
I <sub>IL</sub>	Input leakage current	–	–	1	µA	

## 4.5 I2C-compatible Bus Specifications

Parameter	Operation
Touchscreen Controller Address	0x4A
Navigation Key Controller Address	0x1B
Maximum bus speed (SCL)	400 kHz
I2C Specification	Version 2.1

## 4.6 LCM Specification

Specifications in this section apply only to the LCD panel (PDA P/N: 91-00055-A0).

### 4.6.1 LCM Parameters

Parameter	Value
Display Size	4.3in
LCD Type	$\alpha$ -Si TFT active matrix
Display Mode	Normally White, Transmissive
Resolution	480 x RGB x 272
View Direction (Best Image)	12 o'clock
Dimensions	105.5mm (H) x 67.2mm (W) x 3mm (T)
Active Area	95.04mm (W) x 53.856mm (H)
Dot Pitch	0.198mm (W) x 0.198mm (H)
Pixel Arrangement	RGB Stripe
Display Colors	16.7M
Interface	Digital (TTL)
Driver	Himax 8257-A
Weight	78g

#### 4.6.2 LCM Absolute Maximum Specifications

Parameter	Description	Min	Max	Units
V <sub>CC</sub>	Power Voltage	-0.3	4.5	V
I <sub>LED</sub>	LED Current	0	25	mA
V <sub>I</sub>	Input Voltage	- 0.3	4.5	V
T <sub>STG</sub>	Storage temperature	-30	80	°C
T <sub>OP</sub>	Operating temperature	-20	70	°C

 **CAUTION:** Stresses beyond those listed under LCM *Absolute Maximum Specifications* may cause permanent damage to the device. This is a stress rating only and functional operation of the device at these or other conditions beyond those indicated in the operational sections of this specification are not implied. Exposure to absolute maximum specification conditions for extended periods may affect device reliability.

#### 4.6.3 LCM DC Specifications

Parameter	Description	Min	Typ	Max	Units
V <sub>CC</sub>	Power Supply	3.1	3.3	3.5	V
I <sub>CC</sub>	Current Consumption	-	-	25	mA
V <sub>IL</sub>	Low input logic level	0	-	0.2 V <sub>CC</sub>	V
V <sub>IH</sub>	High input logic level	0.8 V <sub>CC</sub>	-	V <sub>CC</sub>	V

#### 4.6.4 LCM Optical Characteristics

Backlight On (Transmissive Mode).

Parameter	Description	Min	Typ	Max	Units
L	Luminance	-	600	-	cd/m <sup>2</sup>
Y <sub>U</sub>	Luminance uniformity	80	-	-	%
CR	Contrast Ratio	-	500	-	
T <sub>OFF</sub> + T <sub>ON</sub>	Response Time (90% to 10% + 10% to 90%)	-	30	45	ms
W <sub>X</sub>	Color Chromaticity	0.23	0.28	0.33	-
W <sub>Y</sub>		0.25	0.30	0.35	-

#### 4.7 Power Consumption

Vdd (V)	Mode	Idd (mA)
+3.3Vdc	maXTouch controller in Free Run, LCD backlight on maximum intensity	200 max

#### 4.8 Part Number

Part Number	Description
90-00123-A0	TM4301B: 4.3in PCAP Touch Module

## 5 I2C Basics (I2C-compatible Operation)

### 5.1 Interface Bus

The device communicates with the host over an I<sup>2</sup>C-compatible bus, in accordance with version 2.1 of the I<sup>2</sup>C specification. The following sections give an overview of the bus; more detailed information is available from [www.i2c-bus.org](http://www.i2c-bus.org). Devices are connected to the I<sup>2</sup>C-compatible bus as shown in Figure 5 both bus lines are connected to Vdd via pull-up resistors. The bus drivers of all I<sup>2</sup>C-compatible devices must be open-drain type. This implements a wired “AND” function that allows any and all devices to drive the bus, one at a time. A low level on the bus is generated when a device outputs a zero.

**Figure 5. I<sup>2</sup>C-compatible Interface Bus**

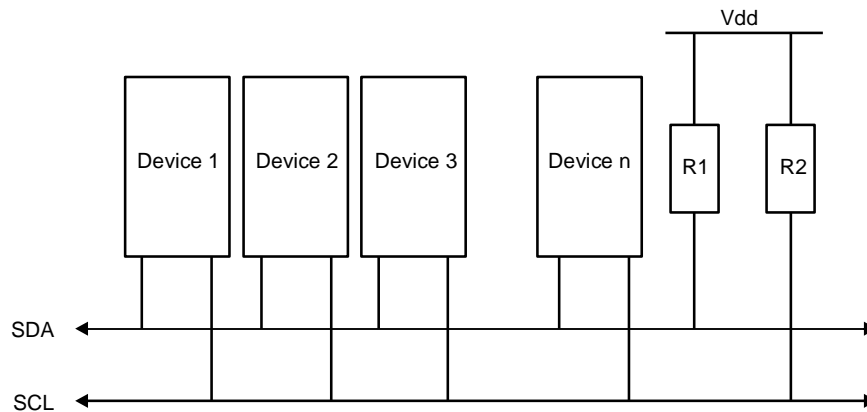

### 5.2 Transferring Data Bits

Each data bit transferred on the bus is accompanied by a pulse on the clock line. The level of the data line must be stable when the clock line is high; the only exception to this rule is for generating START and STOP conditions.

**Figure 6. Data Transfer**

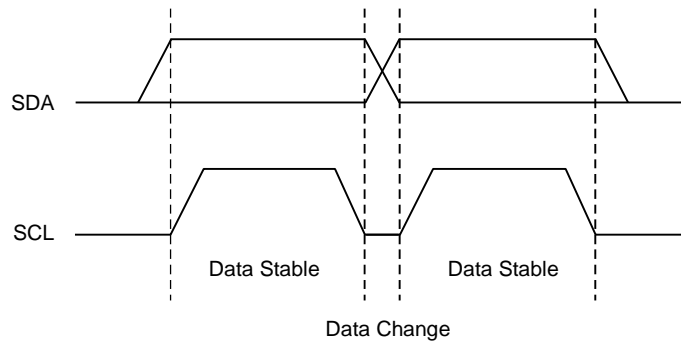

### 5.3 START and STOP Conditions

The host initiates and terminates a data transmission. The transmission is initiated when the host issues a START condition on the bus, and is terminated when the host issues a STOP condition. Between the START and STOP conditions, the bus is considered busy. As shown in Figure 7 START and STOP conditions are signaled by changing the level of the SDA line when the SCL line is high.

**Figure 7. START and STOP Conditions**

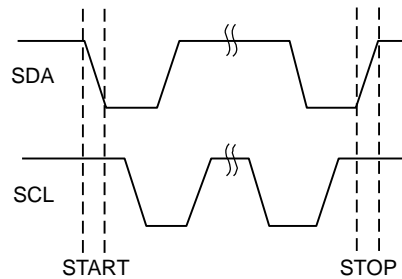

## 5.4 Address Byte Format

All address bytes are 9 bits long. They consist of 7 address bits, one READ/WRITE control bit and an acknowledge bit. If the READ/WRITE bit is set, a read operation is performed. Otherwise a write operation is performed. An address byte consisting of a slave address and a READ or a WRITE bit is called SLA+R or SLA+W, respectively. When the device recognizes that it is being addressed, it acknowledges by pulling SDA low in the ninth SCL (ACK) cycle.

The most significant bit of the address byte is transmitted first.

**Figure 8. Address Byte Format**

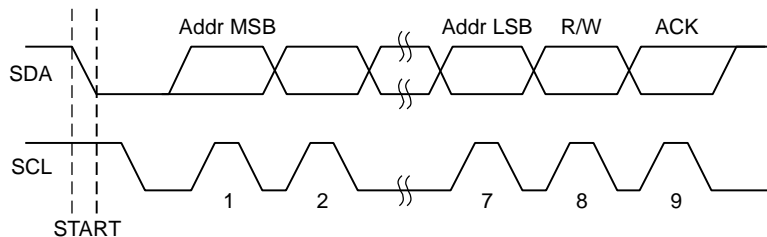

## 5.5 Data Byte Format

All data bytes are 9 bits long, consisting of 8 data bits and an acknowledge bit. During a data transfer, the host generates the clock and the START and STOP conditions. The slave device is responsible for acknowledging the reception. An acknowledge (ACK) is signaled by the slave device pulling the SDA line low during the ninth SCL cycle. If the slave device leaves the SDA line high, a NACK is signaled.

**Figure 9. Data Byte Format**

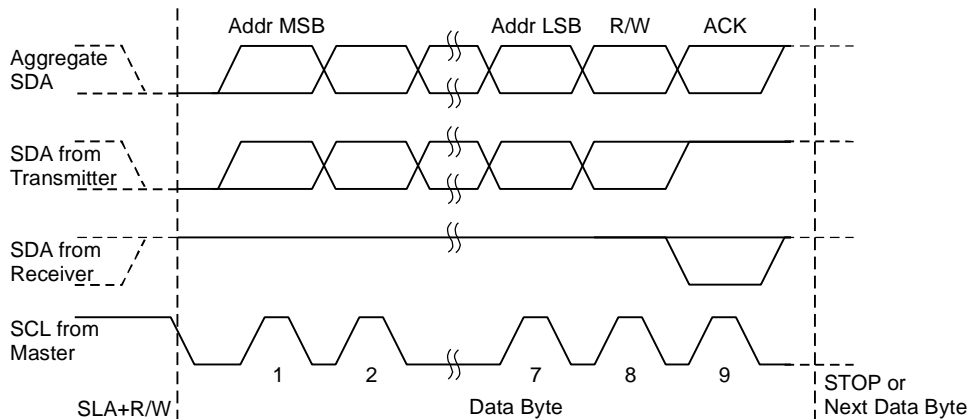

## 5.6 Combining Address and Data Bytes into a Transmission

A transmission consists of a START condition, an SLA+R or SLA+W, one or more data bytes and a STOP condition. The wired “ANDing” of the SCL line is used to implement handshaking between the host and the device. The device extends the SCL low period by pulling the SCL line low whenever it needs extra time for processing between the data transmissions.

Figure 10 shows a typical data transmission. Note that several data bytes can be transmitted between the SLA+R or SLA+W and the STOP.

**Figure 10. Byte Transmission**

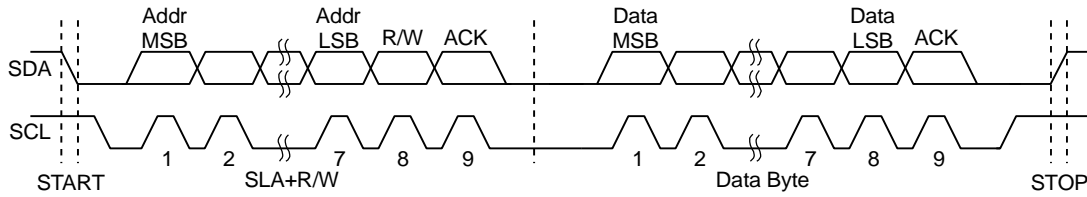

## 6 Revision History

Revision No.	History
Rev A0	Initial Release



## 7 Notes



email: [sales@pdaatl.com](mailto:sales@pdaatl.com)

**Precision Design Associates, Inc.**

645 Hembree Parkway, Suite G  
Roswell, GA 30076  
USA

tel: (770)-664-0448



url: <http://www.pdaatl.com>

© 2016 Precision Design Associates. All rights reserved. Atmel®, Atmel logo and combinations thereof, maXTouch®, QTouch®, and others are registered trademarks of Atmel Corporation or its subsidiaries. Other terms and product names may be registered trademarks or trademarks of others.