

DESCRIPTION		KEY FEATURES
<p>The LX2260 is a high brightness multi-channel LED driver, designed for automotive display illumination. It offers the designer a high degree of flexibility to accommodate different LED configurations (white or RGB), drive currents, input and output voltages while providing a high degree of control, protection and fault management of the system.</p> <p>The LX2260 is very well suited for applications where high brightness LED backlighting is combined with a wide dimming range and high reliability such as in Automotive Infotainment, Marine or Cockpit applications.</p> <p>The LX2260 driver supports up to 4 independent LED strings and can be integrated in systems supporting up to 40W. The drive current of each string can be programmed up to 500mA, with a typical channel-to-channel matching accuracy within ± 1.5 percent. The FETs of the boost converter and each LED current sink are external to provide the flexibility and scalability to accommodate a variety of LED configurations as well as to provide optimal thermal management of the system.</p> <p>Dimming inputs providing either independent control of several white LED strings or color mixing capability for optimal light temperature control. PWM frequency of up to 25kHz is supported to avoid audible noise.</p>	<p>The LX2260 has the unique capability to automatically adjust its operation according to the instantaneous input and output voltage requirements to operate in a boost, buck-boost, or buck converter mode (this is not a traditional buck/boost circuit) thus automatically maintaining the optimally chosen LED current regulation.</p> <p>Fault conditions can be reported through a digital 2 wires serial bus interface (I2C and SMBus compatible) and include LED short, LED open, and IC over temperature indicators as well as information about the LED string voltage.</p> <p>The IC also provides externally programmable LED current rise and fall time that can be used to optimize system EMI.</p> <p>The LX2260 is designed to provide protection as well as continued operation in case of several fault conditions (StayLIT™). Among the protection features we offer output short circuit protection, over-voltage protection, and over-temperature shutdown. In addition, with the use of an external thermistor to sense the LED temperature, the LED current can be compensated to stay within a given LED temperature profile.</p>	<ul style="list-style-type: none"> ▪ Four LED Channels with Independent PWM Control ▪ Up to 500mA LED Current per Channel with External Power Components for Optimal Design and Thermal Management ▪ $\pm 3\%$ Current Setting Accuracy ▪ 1.5% Channel to Channel Current Matching ▪ Minimum +90% efficiency ▪ Programmable LED Current Amplitude via SMBus or I2C ▪ Unique Auto Buck, Boost, and Buck-Boost Mode Transition ▪ Analog Dimming via Light Sensor (Ambient or RGB Light) or Thermistor ▪ Wide Digital Dimming Range (up to 3000:1) ▪ SMBus and I2C Compatible Digital Diagnostic Reporting <ul style="list-style-type: none"> ▪ LED Fault Status ▪ String Voltage Monitoring ▪ LED Over Temperature Warning & Protection ▪ Multiple Protection including Short Circuit, Over Voltage and Over Temperature Protection ▪ Programmable LED Current Rise/Fall Time for EMI Control ▪ Automotive Grade <ul style="list-style-type: none"> ▪ AEC-Q100 Qualification ▪ 40V Load Dump Resistance ▪ -40°C to $+85^{\circ}\text{C}$ Ambient Temperature Range
<p>IMPORTANT: For the most current data, consult MICROSEMI's website: http://www.microsemi.com;</p>		APPLICATIONS <ul style="list-style-type: none"> ▪ Automobile display illumination (cluster instruments, monitors, rear-seat entertainment systems) ▪ Displays for Consumer electronics ▪ White or RGB LED Displays

PACKAGE ORDER INFO		THERMAL DATA
T_A ($^{\circ}\text{C}$)	LQ Plastic 5 x 7 mm ² QFN 38-pin RoHS Compliant / Pb-free	$\theta_{JA} = 19.3^{\circ}\text{C/W}$ THERMAL RESISTANCE-JUNCTION TO AMBIENT
-40 $^{\circ}\text{C}$ to 85 $^{\circ}\text{C}$	LX2260ILQ	Junction Temperature Calculation: $T_J = T_A + (PD \times \theta_{JA})$. The θ_{JA} numbers are guidelines for the thermal performance of the device/pc-board system. All of the above assume no ambient airflow.
<small>Note: Available in Tape & Reel. Append the letters "TR" to the part number. (i.e. LX2260ILQ-TR)</small>		

ABSOLUTE MAXIMUM RATINGS
PACKAGE PIN OUT

Supply Input Voltage VCC, Sense, PFET, VH, VD1-4, EN, VLED-0.3V to 44V
 VH to VCC - 6V
 VL to GND-0.3V to 6V
 SDA, SCLK, PWM1-4, FFLAG-0.3V to 6V
 All other pins -0.3V to VL+0.3V
 Maximum Junction Temperature 150°C
 Storage Temperature Range-65°C to 150°C
 Peak Package Solder Reflow Temperature (40 seconds maximum exposure) 260°C

Notes: Exceeding these ratings could cause damage to the device. All voltages are with respect to GND. Currents are positive into, negative out of specified terminal. These are stress ratings only and functional operation of the device at these or any other conditions beyond those indicated under "Recommended Operating Conditions" are not implied. Exposure to "Absolute Maximum Ratings" for extended periods may affect device reliability.

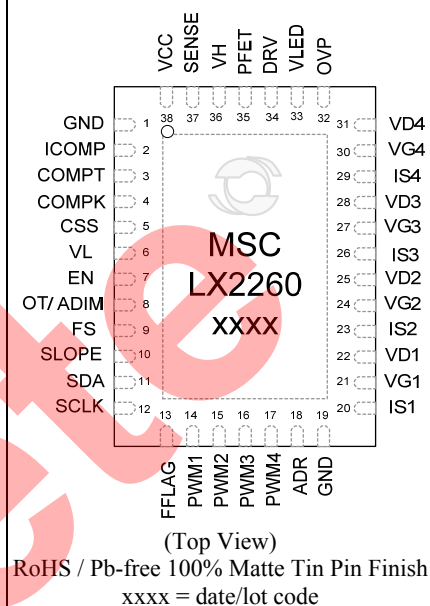
FUNCTIONAL PIN DESCRIPTION

Pin Name	Pin #	Description
GND	1	GND pin: The external NFET for DC-DC converter should return to this GND
ICOMP	2	Power converters current slope compensation. Connect a resistor from this pin to GND to compensate current slope. See "slope compensation section" for detail.
COMPT	3	Boost Mode Compensation: Connect a resistor from this pin and the junction of the COMPK resistor and capacitor for auto tri-mode design.
COMPK	4	Buck and Buck-Boost mode Compensation. Connect a capacitor in series with a resistor across this pin and GND. If needed, another capacitor connected from this pin to GND for type II compensation
CSS	5	Feedback Soft-start: Connect a capacitor 4.7µF typical from this pin and GND.
VL	6	5V power supply output – Power Pin – Provides a regulated 5V typical to the internal and external 5V circuits. Typical 2mA current source for external use.
EN	7	Enable Input. Pull low to put the system into sleep mode. If not used must tie to VCC.
OT/ADIM	8	LED Temperature Compensation/Analog Dimming: This input is used for LED temperature compensation. The LED current amplitude will reduce proportional with LED ambient temperature. The start of compensation is programmable with an external resistor and a thermistor. Connect pin to GND to force 100% output current when thermal compensation is not used. By setting 1 on REG08<7>, this pin becomes analog dimming input (ADIM) which has 0V to 2V control range. Connect ADIM to GND to force 100% output current when analog dimming is not used.
FS	9	Oscillator Frequency Setting pin. Connect a resistor R _{FS} between FS to GND to set the buck/boost frequency using the following formula: Freq [kHz] = 66000/R _{FS} where R is in kΩ.

FUNCTIONAL PIN DESCRIPTION

Pin Name	Pin #	Description
SLOPE	10	LED current rise/fall time programmable pin. Connect a resistor from this pin to GND to program LED current rise/fall time for EMI purpose. If not used, tie this pin to 5V.
SDA	11	Serial Data In/Output. Read data for fault conditions, LED string status via drain voltage, VLED voltage. SDA also can be used to set the LED peak current amplitude by writing to register 08h. Connect to GND if SDA is not used.
SCLK	12	Serial Clock Input. Maximum clock is 100kHz. Connect to GND if not used.
FFLAG	13	Fault signal output. Open drain output. This pin goes low when a fault condition is detected.
PWM1-4	14-17	Pulse Width Modulated dimming signal – Signal input. PWM input can be tied together for a common PWM signal or use for individual PWM control.
ADR	18	Address Setting: connect to VL, GND or leave it open for three different address choices. Refer to the address table below.
GND	19	GND pin
IS1-4	20,23, 26,29	LED current setting. – Program this pin with an external resistor to set the LED current with 300mV internal reference voltage. $I_{LED} = 300mV/R_{IS}$
VG1-4	21,24, 27,30	Gate Drive – CMOS Output Pin: Connect to the gate of the external NMOSFET current sink. Any unused pins must be tied to ground to distinguish between intentionally unused and LED failed open.
VD1-4	22,25, 28,31	Drain – Signal Pin – This connects to Drain pin of the external N-MOSFET switch. The boost output voltage regulates based on the lowest VD, and the lowest voltage is kept at 0.9V (typical). Any unused pins can be left open.
OVP	32	Over Voltage Protection – Signal input: An external voltage divider sets the maximum LED voltage. System will stop switching when OVP limit hits, and resume when it goes lower than the limit.
VLED	33	LED voltage. Connect this pin directly to common anode strings voltage.
DRV	34	Low-side NFET gate drive: Connect to the gate of the N-channel MOSFET
PFET	35	High-side PMOS gate drive: Connect to gate of a PFET. When the boost output short detected or EN signal low, PFET will open. Otherwise, PFET is a converter switch in buck or buck-boost mode.
VH	36	High side power rail. Connect a 1 μ F 10V capacitor from this pin to VCC.
SENSE	37	Converters current sense negative pin. The differential input voltage across R _{SENSE} resistor used to set the peak inductor current. Use Kelvin connection directly to the R _{SENSE} output side
VCC	38	Power supply input – Provides power to the IC. Must be closely decoupled to ground with ceramic capacitors.

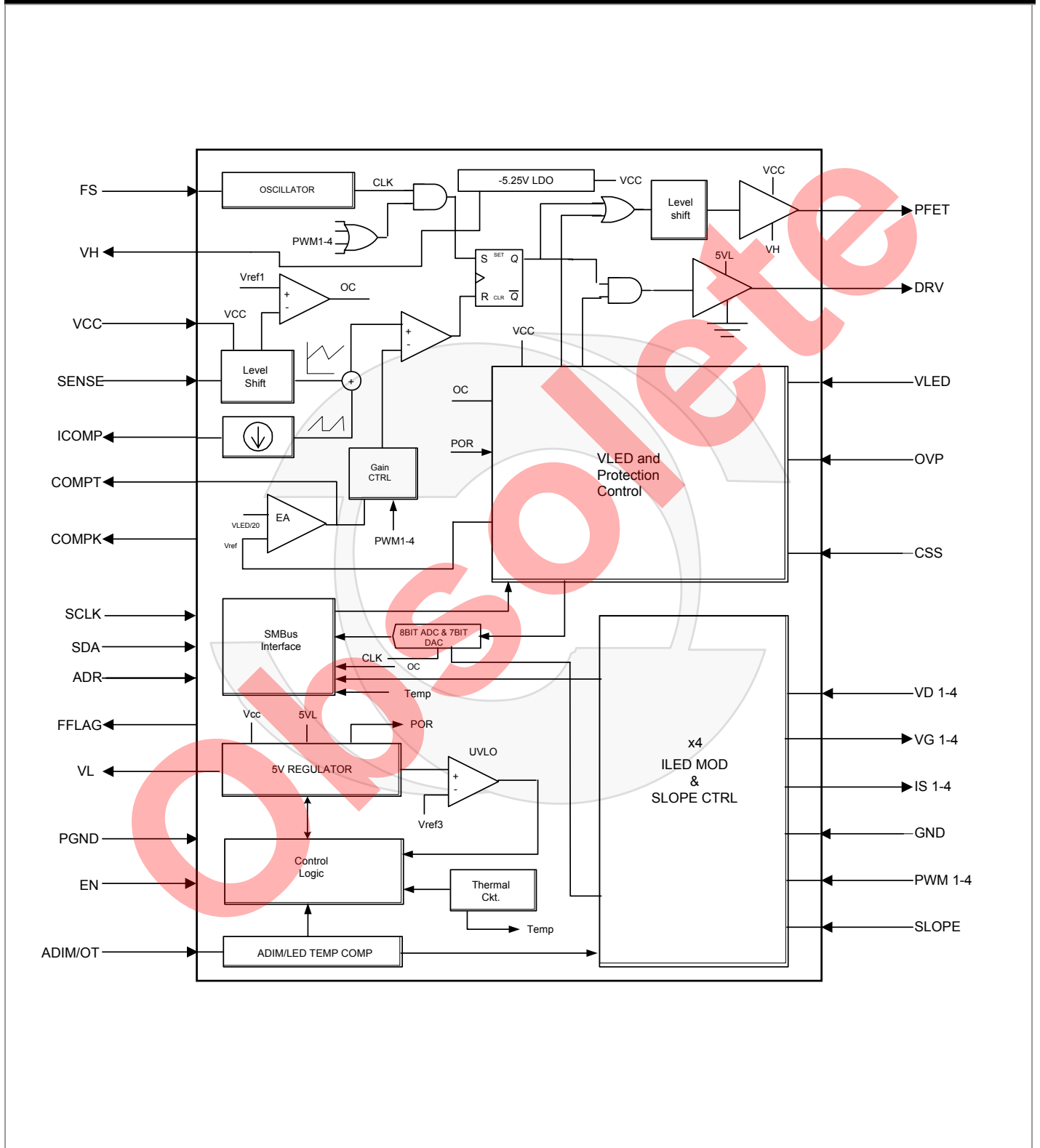
SIMPLIFIED BLOCK DIAGRAM

ELECTRICAL CHARACTERISTICS

Unless otherwise specified, the following specifications apply over the operating ambient temperature of $-40^{\circ}\text{C} \leq T_A \leq 85^{\circ}\text{C}$ and the following test conditions: $V_{CC} = 12\text{V}$; $V_{OT} = 0\text{V}$, $EN = 3\text{V}$, $R_{FS} = 100\text{k}\Omega$, $R_{SLOPE} = 82.5\text{k}\Omega$, Typical values are at $T_A = +25^{\circ}\text{C}$

Parameter	Symbol	Test Conditions / Comment	Min	Typ	Max	Units
Input Power Supply						
Input Voltage	VCC	Withstand voltage VCC = 40V	6		28	V
Quiescent current	ICC _{ON}	EN > 2V, No PFET & NFET connected			10	mA
Sleep current	ICC _{SLEEP}	EN < 0.8V, VCC = 28V			25	μA
Control and Logic						
EN Logic High	V _{ENH}		2			V
EN Logic Low	V _{ENL}				0.8	V
EN Current High	I _{ENH}	EN = 3.3V			5	μA
EN Current Low	I _{EN-L}	EN < 0.8V			5	μA
Address High Input	V _{ADRH}		VL-0.8			V
Address Low Input	V _{ADRL}				0.8	V
Address Open	V _{ADRO}			VL/2		V
Address Input Low Current	I _{ADRH}		-20	-7		μA
Address Input High Current	I _{ADRL}			7	20	μA
FFLAG Output Low Voltage	V _{FFLAGH}	I _{LOAD} = 3mA			0.4	V
FFLAG Output High Leakage Current	V _{FFLAGL}	V _{FFLAG} = 5.5V			10	μA
DC/DC PWM Error Amplifier						
Peak Output Current	I _{OUT}			+/-40		μA
Output Resistance	R _{OUT}			4000		kΩ
Forward Transconductance	gm	At EA inputs (I _{OUT} /(V _{LED} /20-V _{CSS}))		120		μmho
COMP Switch On Resistance		V _{COMPT} = V _{COMPK} = 1.6V		0.5		kΩ
Soft Start/Drain Voltage Sense Error Amplifier						
CSS Source Sink Peak Current	I _{CSS}	Lowest VD > 700mV		+/-20		μA
		Lowest VD < 700mV		120		
Forward Transconductance	gm			80		μmho
Output Resistance				5000		kΩ
Valid Output Voltage Range	V _{CSS}	1/20 of V _{LED}	0.5		2	V
Start Up Time	T _{SU}	C _{CSS} = 2.2μF, R _{ISX} = 2Ω, V _{IS} setting 300mV, 100% PWM, at IS voltage > 90%		5	20	mS
Pulse Width Modulation Input						
PWM Input Low Voltage	V _{PWM_L}				0.8	V

ELECTRICAL CHARACTERISTICS

Unless otherwise specified, the following specifications apply over the operating ambient temperature of $-40^{\circ}\text{C} \leq T_A \leq 85^{\circ}\text{C}$ and the following test conditions: $V_{CC} = 12\text{V}$; $V_{OT} = 0\text{V}$, $EN = 3\text{V}$, $R_{FS} = 100\text{k}\Omega$, $R_{SLOPE} = 82.5\text{k}\Omega$, Typical values are at $T_A = +25^{\circ}\text{C}$

Parameter	Symbol	Test Conditions / Comment	Min	Typ	Max	Units
PWM Input High Voltage	V_{PWM_H}		2			V
PWM Input Frequency	F_{PWM}		0.1		25	kHz
Minimum PWM Pulse Width	PWM_{MIN}	Digital Dimming; SLOPE = VL	2			μs
		Adjustable Slope Option to set t_R and t_F	2.5			+2 t_R or t_F
PWM Input Pull-down Resistor	PWM_R			100		$\text{k}\Omega$
PWM Input to Output Delay ($V_{IS} = \text{High}$)		SLOPE = VL (minimum t_R , t_F)		6.5		μs
		$R_{SLOPE} = 82.5\text{k}\Omega$ ($t_R, t_F \sim 4\mu\text{s}$)		9		μs
Device Protection						
OVP Threshold Voltage	V_{TH_OVP}		1.87	1.97	2.07	V
Over Temperature Shutdown	T_{OVT_SHDN}	Rising temperature hysteresis, $T_{HYS} = 20^{\circ}\text{C}$, at junction		150		$^{\circ}\text{C}$
Shut Down Recovery	$T_{RECOVERY}$	At junction		130		$^{\circ}\text{C}$
Over Temperature Warning	T_{OVT_WARN}	Rising temperature hysteresis, $T_{HYS} = 15^{\circ}\text{C}$, at junction		120		$^{\circ}\text{C}$
Clear Warning		At junction		105		$^{\circ}\text{C}$
Load Dump Protection	V_{ISET}	V_{IS} setting at 100%, buck-boost transition. $V_{IN}: 10\text{V} \leftrightarrow 40\text{V}$, $dV/dt = 30\text{V/msec}$ For Design Reference Only			360	mV
LED Current Output						
Sink Current Overshoot	V_{ISET_OVERS}	V_{IS} setting at 100% , PWM Dimming For Design Reference Only			5	%
Sink Current Over/Under shoot in transition mode	V_{ISET}	V_{IS} setting at 100% , buck-boost transition. $V_{IN}: 10\text{V} \leftrightarrow 32\text{V}$, $dV/dt = 1\text{V/msec}$ For Design Reference Only			10	%
V-source Pk-Pk Matching Among Strings	$V_{ISET\ 150}$	$R_{sense} = 2\Omega$, $0.8\text{V} \leq VD \leq 3\text{V}$ (note 1) $T_{AMB} = 25^{\circ}\text{C}$, PWM = 100% duty cycle			1.5	%
		$F_{PWM} = 200\text{Hz}$, PWM = 25% duty cycle			3	%
Maximum IS voltage	V_{ISx}	$R_{sense} = 2\Omega$, Average of the four outputs	291		309	mV
		$R_{sense} = 2\Omega$, Each outputs	286.6		313.6	mV
Minimum VD regulation	V_{DX}	At the lowest VD pin, $I_{DS} = 150\text{mA}$	800		1000	mV
IS Input Bias Current	I_{IS}	$V_{IS} = 300\text{mV}$			300	nA
DC Gain	A_{OL}			80		dB
Current Source Driver Opamp						
On State VG Voltage Range	VG_{RANGE}	VG voltage that maintains DC accuracy	1.5		4	V
Off State VG Voltage	VG_{OFF}				0.1	V
VG Sink Current	VG_{SNK}	$V_{VG} = 2.5\text{V}$, $V_{IS} = 0.4\text{V}$, PWM = HIGH		-7		mA
VG Source Current	VG_{SRC}	$V_{VG} = 2.5\text{V}$, $V_{IS} = 0.2\text{V}$, PWM = HIGH		7		mA

ELECTRICAL CHARACTERISTICS

Unless otherwise specified, the following specifications apply over the operating ambient temperature of $-40^{\circ}\text{C} \leq T_A \leq 85^{\circ}\text{C}$ and the following test conditions: $V_{CC} = 12\text{V}$; $V_{OT} = 0\text{V}$, $EN = 3\text{V}$, $R_{FS} = 100\text{k}\Omega$, $R_{SLOPE} = 82.5\text{k}\Omega$, Typical values are at $T_A = +25^{\circ}\text{C}$

Parameter	Symbol	Test Conditions / Comment	Min	Typ	Max	Units
VG Load Capacitance	C_{LG}				1500	pF
LED Current On/Off slope						
SLOPE Reference Voltage	V_{SLOPE}			2		V
I-LED Rise Time	$T_{I-LED\ RISE}$	SLOPE = 5VL $F_{PWM} = 200\text{Hz}$, PWM = 50% duty cycle	1	1.5	2.5	μs
I-LED Fall Time	$T_{I-LED\ FALL}$	$C_{LG} < 500\text{pF}$	1	1.5	2.5	μs
I-LED Rise Time	$T_{I-LED\ RISE}$	$R_{SLOPE} = 82.5\text{k}\Omega$, $T_{RISE}/T_{FALL} = 10\%$ to 90%	3	4.2	5.5	μs
I-LED Fall Time	$T_{I-LED\ FALL}$	$F_{PWM} = 200\text{Hz}$, PWM = 50% duty cycle $C_{LG} < 500\text{pF}$	3	4.2	5.5	μs
LED Temperature Compensation (LED Current Profile)						
OT Start Threshold Voltage	V_{OTTH}	I-LED starts compensation at I-LED = 95% current setting. Register 08h = 01111111; PWM1-4 = High	1.8	2.0	2.2	V
OT Max_Voltage Compensation	V_{OT}	At stop point, I-LED = 15% current setting. Register 08h = 01111111; PWM1-4 = High	3.3	3.5	3.8	V
		And goes down to 6.7% when $V_{TH\ OT} > 4.5\text{V}$. PWM1-4 = High; Register 08h = 01111111	3.5	3.7	3.95	V
OT Input Bias Current	I_{OTIIB}				1	μA
Analog Dimming (Analog dimming can be set via SMBus or Fuse)						
AD Voltage	V_{AD}	I-LED = 95%; PWM1-4 = HIGH; Register 08h = 01111111	1.8	1.9	2.0	V
		I-LED = 6.7%; PWM1-4 = HIGH; Register 08h = 01111111	0.05	0.2	0.34	
AD Input Bias Current	AD_{IIB}		-1		1	μA
Analog Control Output Range	V_{IS}	Register 08h = 01111111, PWM1-4 = High	5		100	%
SMBus LED Peak Current Adjustment						
Adjustment Range	I_{PADJ}	$V_{IS} = 300\text{mV}$ represents maximum current setting	15.4		100	% V_{IS}
Resolution	I_{RES}	2 mV translates out to be 7 bits DAC		2		mV
LED short/open protection						
LED Short Threshold Voltage (note 1)	VDX_{SHORT}	$F_{PWM} = 25\text{kHz}$, Duty cycle $> 7\mu\text{s}$	6.7	7.2	7.7	V
Derated IS Voltage		$VD > 7.75$		10		%
LED Open Threshold Voltage	VDX_{OPEN}	$F_{PWM} = 25\text{kHz}$, PWM = 10% duty cycle		0.24		V
Inductor Over Current protection						
Maximum Short Circuit Current	I_{LSHORT}	With 10m Ω current sense resistor For Design Reference Only		10		A
Over Current Threshold Voltage	V_{OC}	At current sense inputs		90		mV

ELECTRICAL CHARACTERISTICS

Unless otherwise specified, the following specifications apply over the operating ambient temperature of $-40^{\circ}\text{C} \leq T_A \leq 85^{\circ}\text{C}$ and the following test conditions: $V_{CC} = 12\text{V}$; $V_{OT} = 0\text{V}$, $EN = 3\text{V}$, $R_{FS} = 100\text{k}\Omega$, $R_{SLOPE} = 82.5\text{k}\Omega$, Typical values are at $T_A = +25^{\circ}\text{C}$

Parameter	Symbol	Test Conditions / Comment	Min	Typ	Max	Units
SENSE Input						
Sense Input Voltage Range	V_{SENSE}				100	mV
Sense Input Bias Current	I_{SENSE}			0.3		μA
VL Regulator (5.0V)						
VL Output	5V	$6\text{V} \leq V_{CC} \leq 28\text{V}$; no external load	4.75	5.00	5.25	V
VL Source Current	$5V_{CURRENT}$	External load current, $V_{CC} = 6\text{V}$, VL drop by $\leq 5\%$		2		mA
UVLO	VL_{UVLO}	VL rising, $V_{HYS} = 0.50\text{V}$	3.75	4.25	4.65	V
VH (VCC-5.25V) Regulator						
VH Output Voltage	VH	$6\text{V} \leq V_{CC} \leq 28\text{V}$; $0\text{mA} \leq I_{VH} \leq 15\text{mA}$ Reference to VCC	-4.75	-5.25	-5.5	V
UVLO	VH_{UVLO}	VH falling, $V_{HYS} = 0.50\text{V}$. Internal POR activates on VH falling UVLO threshold, reference to VCC		-4.25		V
Oscillator						
FS Reference Voltage	V_{FS}			2		V
Oscillator Frequency	F_{SW}	$R_{FS} = 100\text{k}\Omega$	600	670	740	kHz
Oscillator Frequency Setting Range	F_{RANGE}		400		800	kHz
DC/DC Switching NFET Driver						
DRV Voltage High	V_{DRVH}			5		V
DRV Rise Time	T_{RISE}	$CL = 1000\text{pF}$		26		ns
DRV Fall Time	T_{FALL}	$CL = 1000\text{pF}$		15		ns
Off Voltage	V_{DRVOFF}	$EN = 0\text{V}$		0		V
DC/DC Switching PFET Driver						
PFET High Voltage	V_{PFETH}	$EN = 0\text{V}$, refer to VCC		0		V
PFET Low Voltage	V_{PPFETL}	Refer to VCC		-5.25		V
PFET Rise Time	T_{RISE}	$CL = 1000\text{pF}$		14		ns
PFET Fall Time	T_{FALL}	$CL = 1000\text{pF}$		25		ns
Converter mode condition						
Boost to Buck-Boost Transition	BS-BB	At VLED. VLED falling		13.76		V
Buck-Boost to Boost Transition	BB-BS	At VLED. VLED rising		14.65		V
Buck to Buck-Boost Transition	BK-B	At VLED. VLED rising		9.21		V
Buck-Boost to Buck Transition	BB-BK	At VLED. VLED falling		8.41		V

ELECTRICAL CHARACTERISTICS

Unless otherwise specified, the following specifications apply over the operating ambient temperature of $-40^{\circ}\text{C} \leq T_A \leq 85^{\circ}\text{C}$ and the following test conditions: $V_{CC} = 12\text{V}$; $V_{OT} = 0\text{V}$, $EN = 3\text{V}$, $R_{FS} = 100\text{k}\Omega$, $R_{SLOPE} = 82.5\text{k}\Omega$, Typical values are at $T_A = +25^{\circ}\text{C}$

Parameter	Symbol	Test Conditions / Comment	Min	Typ	Max	Units
Overall System Efficacy	η	$V_{IN} = 12\text{V} \& 26\text{V}$, VS setting at 100%, PWM = 100% (Boost mode & Buck Mode) For Design Reference Only	90			%
SMBus						
SDA, SCLK Input Low Voltage	I_{LV}				0.7	V
SDA, SCLK Input High Voltage	I_{HV}		2			V
SDA, SCLK Input Hysteresis	I_{HYS}			100		mV
SDA,SCLK Input Bias Current	I_{IB}		-5		+5	μA
SDA Output Low Sink Current	O_{SNK}	$V_{SDA} = 0.4\text{V}$	4			mA
SMBus Frequency	F_{SMBUS}		10		100	kHz
SMBus Free time	T_{BUF}		4.7			μs
SCLK Serial Clock High Period	T_{HIGH}		4			μs
SCLK Serial Clock Low Period	T_{LOW}		4.7			μs
Start Condition Set-up Time	$T_{SU:STA}$		4.7			μs
Start Condition Hold-up Time	$T_{HD:STA}$		4			μs
Stop Condition Set-up Time from SCLK	$T_{SU:STO}$		4			μs
SDA Valid to SCLK Rising Edge Set-up Time, Slave Clocking Data	$T_{SU:DAT}$		250			ns
SCLK Falling Edge to SDA Transition	$T_{HD:DAT}$		0			ns
SCLK Falling Edge to SDA Valid, Reading Out Data	T_{DV}		200			ns

Note: 1. When the different V_{DRAIN} voltages are more than 2V, then a single LED short may shut off the string that has a highest V_{DRAIN} (VD hits the limit). However V_{SOURCE} pk-pk matching will not be effected in this circumstance.

SERIAL INTERFACE
SMBus INTERFACE

LX2260 is a nine-register device which uses SMBus or I²C protocols to communicate with the host system. All registers are defined as full byte wide. Some registers contain reserved (undefined) bits with a default value of “0”, or are read only bits that are status indicators. Two of the nine registers are capable of both read and write, and seven registers are read only. See the LX2260 Register Definitions section for details.

The LX2260 communicates over the SMBus and operates in a “slave” mode receiving commands and sending / receiving data to / from the host or “master”. Only standard two-wire SMBus and I²C compatible serial bus and protocols may be used for this device. The LX2260 can be configured for one of the three addresses by connecting the ADR input pin to ground, V_{DD}, or simply leaving it OPEN.

Address Strapping Codes

Option #	ADR	Address
1	GND	0101 100b
2	OPEN	0101 110b
3	V _{DD}	0101 111b

In this document, the SMBus address occupies high seven bits of an eight bit field on the bus, the low bit is always the R/W bit.

Address = 0101100xb

1	7	1	1	8	1	1
S	Slave Address	Wr	A	Data Byte	A	P
	0 1 0 1 1 0 0	0				

Address = 0101110xb

1	7	1	1	8	1	1
S	Slave Address	Wr	A	Data Byte	A	P
	0 1 0 1 1 1 0	0				

Address = 0101111xb

1	7	1	1	8	1	1
S	Slave Address	Wr	A	Data Byte	A	P
	0 1 0 1 1 1 1	0				

SMBus PROTOCOL

The only required command protocols are SMBus Send Byte, Receive Byte, Read Byte / Word, and the Write Byte / Word protocols.

Writes to registers can be performed by either the SMBus Write Byte / Word protocols and / or by internal IC logic, depending on the register type.

Read can be performed on all registers by issuing the Read Byte / Word protocol. Read Only registers can be written only by internal logics. Their contents will not be affected by SMBus write commands.

When LX2260 is initially powered, it will first test the address selection pin input to determine its own address and then look for its unique address each time it detects a “Start Condition”. If the address does not match, the LX2260 ignores all bus activity until it encounters another “Start Condition”.

SMBus Packet Protocol Diagram Element Key

S	Slave Address	Wr	A	Data Byte	A	P
			X		X	

S Start Condition

Rd Read (bit value of 1)

Wr Write (bit value of 0)

A Acknowledge (‘0’ for an ACK, or ‘1’ for a NACK)

P Stop Condition

Command Code Register Address
 Master-to-Slave Slave-to-Master

Protocols used to communicate with LX2260 must be per standard SMBus specification version 2.0 or higher.

SERIAL INTERFACE

REGISTER 04h		LED voltage monitoring			DEFAULT VALUE 0x00		
VLED	VLED	VLED	VLED	VLED	VLED	VLED	VLED
Bit 7 (R)	Bit 6 (R)	Bit 5 (R)	Bit 4 (R)	Bit 3 (R)	Bit 2 (R)	Bit 1 (R)	Bit 0 (R)

BIT FIELD	DEFINITION	DESCRIPTION
Bit 0-7 (R)	LED voltage	8-bit LED voltage monitoring. 256 steps for 67.9V. (bit 7 is MSB)

REGISTER 05h:		String 1&2 Status Register			DEFAULT VALUE 0x00		
String #2 not Used	String #1 not Used	S1_OV	S1_OPEN	S1_NOTUSE	S2_OV	S2_OPEN	S2_NOTUSE
Bit 7 (W)	Bit 6 (W)	Bit 5 (R)	Bit 4 (R)	Bit 3 (R)	Bit 2 (R)	Bit 1 (R)	Bit 0 (R)

BIT FIELD	DEFINITION	DESCRIPTION
Bit 7	String #1 not Used	Set 1 when string #1 is not used to mask string faults on the string. Bit 6 and 7 are written to register 05h by the systems via SMBus to let the LX2260 know the unused string so the LX2260 can remove it from the fault detection/reporting. At power up system must disregard fault reporting and FFLAG (software timer) until the systems has finished setting string not used bit (set bit 6 and or 7 to high) and have received acknowledgement from LX2260. LX2260 sends an acknowledgement after masking string fault.
Bit 6	String #2 not Used	Set 1 when string #2 in not used to mask string faults on the string.
Bit 5	S1_OV	String 1 Over Voltage (1 = VD > 6.75V)
Bit 4	S1_OPEN	String 1 Open (1 = string open)
Bit 3	S1_NOTUSE	String 1 status (1 = string is not used)
Bit 2	S2_OV	String 2 Over Voltage (1 = VD > 6.75V)
Bit 1	S2_OPEN	String 2 Open (1 = string open)
Bit 0	S2_NOTUSE	String 2 status (1 = string is not used)

BIT FIELD	DEFINITION	DESCRIPTION					
REGISTER 06h		String 3&4 Status Register			DEFAULT VALUE 0x00		
String #4 not Used	String #3 not Used	S3_OV	S3_OPEN	S3_NOTUSE	S4_OV	S4_OPEN	S4_NOTUSE
Bit 7 (W)	Bit 6 (W)	Bit 5 (R)	Bit 4 (R)	Bit 3 (R)	Bit 2 (R)	Bit 1 (R)	Bit 0 (R)
Bit 7	String #3 not Used	Set 1 when string #3 in not used to mask string faults on the string. Bit 6 and 7 are written to register 06h by the systems via SMBus to let the LX2260 know the unused string so the LX2260 can remove it from the fault detection/reporting. At power up system must disregard fault reporting and FFLAG (software timer) until the systems has finished setting string not used bit (set bit 6 and or 7 to high) and have received acknowledgement from LX2260. LX2260 send acknowledgement after masking string fault					
Bit 6	String #4 not Used	Set 1 when string #4 in not used to mask sting faults on the string.					
Bit 5	S3_OV	String 3 Over Voltage (1 = VD > 6.75V)					
Bit 4	S3_OPEN	String 3 Open (1 = string open)					
Bit 3	S3_NOTUSE	String 3 status (1 = string is not used)					
Bit 2	S4_OV	String 4 Over Voltage (1 = VD > 6.75V)					
Bit 1	S4_OPEN	String 4 Open (1 = string open)					
Bit 0	S4_NOTUSE	String 4 status (1 = string is not used)					

SERIAL INTERFACE TIMING

REGISTER 07h			Faults Register		DEFAULT VALUE 0x00		
RESERVED	RESERVED	RESERVED	RESERVED	OC SHDN	OC	OTP	T Warning
Bit 7 (R)	Bit 6 (R)	Bit 5 (R)	Bit 4 (R)	Bit 3 (R/W)	Bit 2 (R)	Bit 1 (R/W)	Bit 0 (R)

BIT FIELD	DEFINITION	DESCRIPTION
Bit 3	OC SHDN	OC shutdown (1 = OCP shut down, 0 = OC SHDN OK). Reset after reading or by En = Low
Bit 2	OC	Input OC (1 = over current condition, 0 = OC OK). Reset after reading or by En = Low
Bit 1	OTP	OTP Shutdown (1 = OTP shut down, 0 = T _{OK}). (note 1)
Bit 0	T WARNING	Temperature warning (1 = T _{WARNING} , 0 = T _{OK}). (note 2)

REGISTER 08h			ILED Setting Register			DEFAULT VALUE 0x7F	
ADIM	Bit6	Bit5	Bit4	Bit3	Bit2	Bit1	Bit0
Bit 7 (R/W)	Bit 6 (R/W)	Bit 5 (R/W)	Bit 4 (R/W)	Bit 3 (R/W)	Bit 2 (R/W)	Bit 1 (R/W)	Bit 0 (R/W)

BIT FIELD	DEFINITION	DESCRIPTION
Bit 7	ADIM	Analog Dimming Mode setting (0 = OT, 1 = ADIM)
Bit 6:0	ILED bit6:0	To program LED current setting reference voltage, see note below.

Register 08h: LED Peak Current Adjustment (7 bits used for 128 steps)							
Bit 6	Bit 5	Bit 4	Bit 3	Bit 2	Bit 1	Bit 0	V _{IS} (mV)
0	0	0	0	0	0	0	46
0	0	0	0	0	0	1	48
0	0	0	0	0	1	0	50
0	0	0	0	0	1	1	52
0	0	0	0	1	0	0	54
↓	↓	↓	↓	↓	↓	↓	↓
1	1	1	1	1	1	0	298
1	1	1	1	1	1	1	300

Default LED reference is 300mV regardless SDA/SCLK state at POR.

Note:

1. OTP bit change state from “0” to “1” and latched when the real time OTP changes from “0” to “1”.
2. T WARNING bit changes state from “0” to “1” and latched when the real time T WARNING change from “0” to “1”.

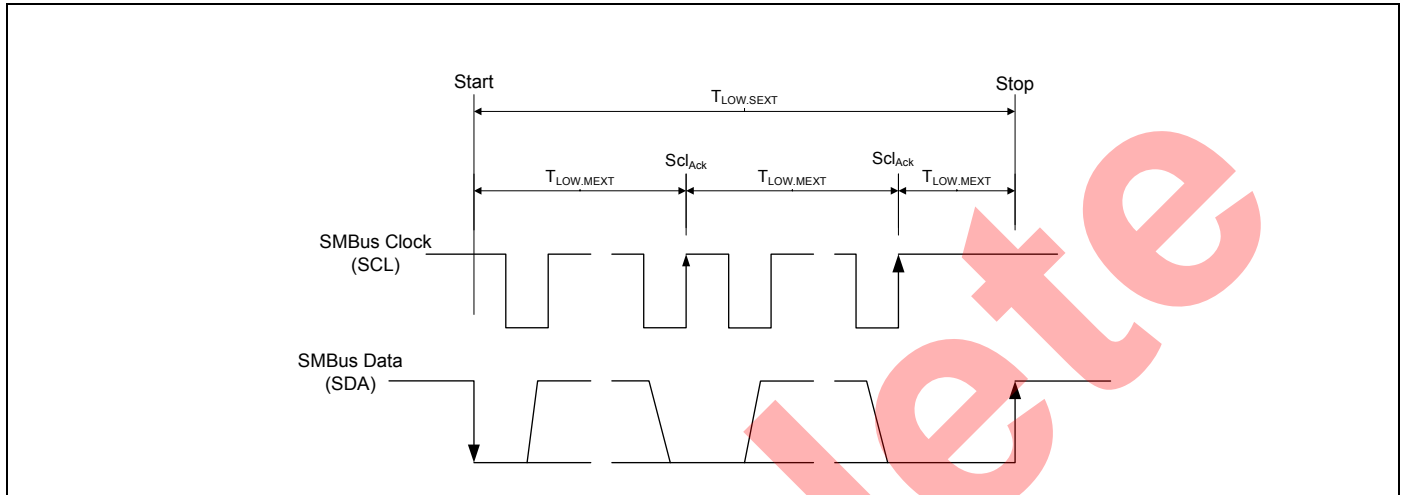
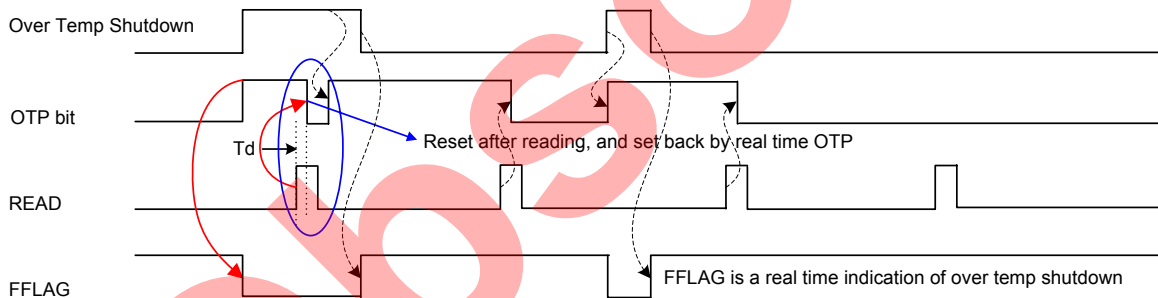
SERIAL INTERFACE TIMING
Timeout Measurement Interval

Faults Timing Diagram
OTP Timing (Bit 1, Reg 07h)

FFLAG stays low when the chip is in over temperature shutdown mode.

OTP bit is latched by over temperature warning signal.

FFLAG and OTP reset after reading and real time OTP is low. (Real time OTP not show)

There are some Tdelay (Td) from real time OTP "1" to set OTP & FFLAG, as well as from end read cycle to reset OTP and FFLAG. Td must < 1µsec.

This timing diagram shows relationship between Over temperature Shutdown output and OTP bit, FFLAG only without any other fault conditions. In an actual application, FFLAG will not represent Over Temp Shutdown from temperature monitor because FFLAG is a NORed output of all faults and over temperature warning is always true when Over Temp Shutdown is true.

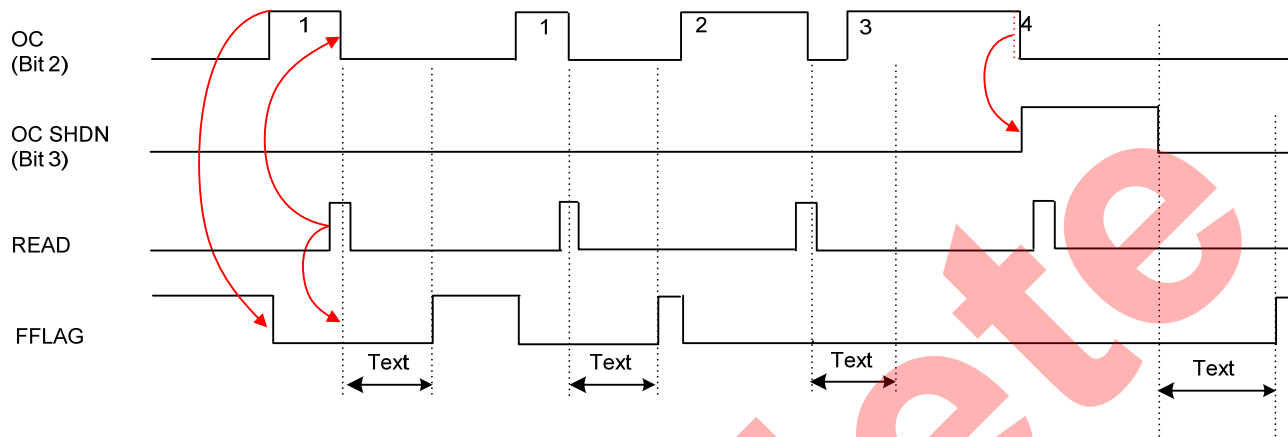
SERIAL INTERFACE TIMING
OC Timing

FFLAG is Low whenever OC or OC SHDN occurs and extended by an internal timer.
 OC and FFLAG register bits are reset after reading. (Real time OC not shown)
 Fault bits are set back when the fault conditions present.

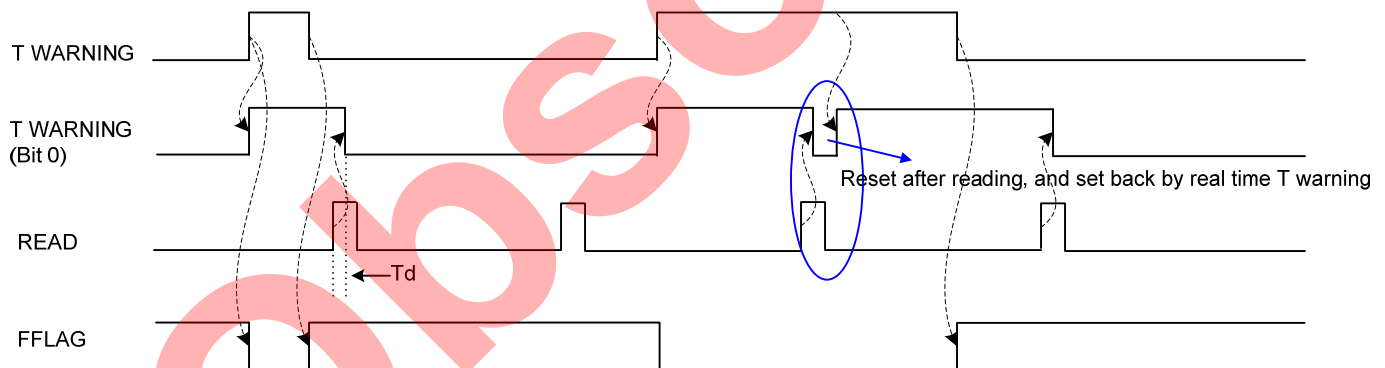
T Warning Timing (bit 0 Reg 07h)

FFLAG is Low whenever T Warning occurs.
 T Warning bit is reset after read access and when real time T warning is low.
 There are some T_{delay} (T_d) from real time T WARNING "1" to set T WARNING & FFLAG, as well as from end read cycle to reset T WARNING & FFLAG. T_d must < 1 μ sec.

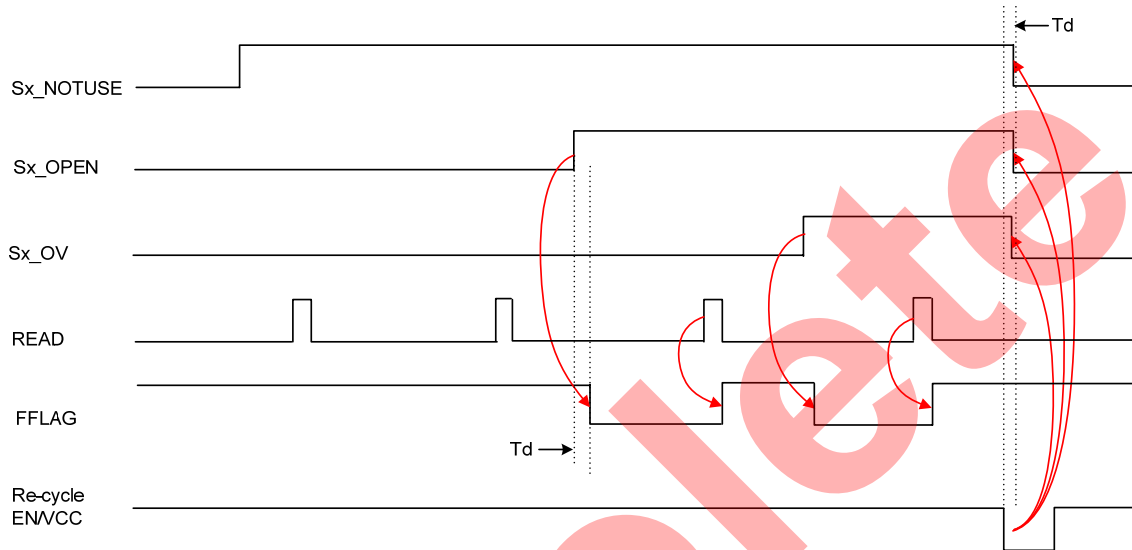
SERIAL INTERFACE TIMING
Strings Status Timing Diagram
String Status

FFLAG is Low whenever String OV or String OPEN occurs.
 FFLAG reset after reading.
 Strings status are latched and be reset by recycling EN signal or Vcc
 There are some Tdelay (T_d) from String OPEN/OV high to set FFLAG, as well as from re-cycle EN/VCC to reset String OPEN/OV and FFLAG. T_d must $< 1\mu\text{sec}$.

THEORY OF OPERATION
Introduction

The LX2260 is a fixed frequency current-mode PWM controller designed to regulate the necessary voltage to drive an LED array. Depending on the input voltage and the required LED string voltage, the LX2260 will decide to operate in boost converter mode, buck converter mode, or buck-boost converter mode with fixed switching frequency from 400kHz to 800kHz, which is programmed by an external resistor. In all modes of operation the LX2260 will regulate to the lowest drain voltages (typ. 0.9V) to minimize the power loss through the external current sink NFETs.

Current Sense Resistor Selection

The voltage across an external input current sense resistor is used for limiting the switching current (coil current) cycle-by-cycle. For $I_{pk_LIMIT} = 10A$ (recommended), then

$$R_{SENSE} = \frac{100mV}{I_{pk_LIMIT}} = \frac{100mV}{10A} = 10m\Omega$$

Inductor Selection

To keep the circuit in constant current mode (CCM), the maximum ripple current should be less than twice the minimum load current. The final value of the inductor will be a compromise between buck and boost modes. Due to the effect of RHP zero on Error Amplifier compensation, select the minimum load = I_{OUT} . The following formulae should be used to calculate the inductor values in both buck and boost modes.

Minimum inductor value for boost converter:

Where $f_s \approx 600kHz$

$$L_{BOOST} \geq \frac{V_{IN} \cdot (V_O - V_I)}{(V_O \cdot f_s \cdot I_O \cdot \% \Delta I)}$$

Where $V_{IN} = V_O/2$, $\% \Delta I = \Delta I/I_O$

Minimum inductor value for buck converter:

$$L_{BUCK} \geq \frac{V_O \cdot (V_I - V_O)}{(V_I \cdot f_s \cdot I_O \cdot \% \Delta I)}$$

Where $V_{IN} = V_{I(MAX)}$, $\% \Delta I = \Delta I/I_O$

The actual mode transition threshold can be calculated by the following equations:

$$\text{Buck-Boost to Buck} = V_{LED} \cong 0.9 \cdot V_{CC} - 1.6 \text{ [V]}$$

$$\text{Buck to Buck-Boost} = V_{LED} \cong 0.9 \cdot V_{CC} - 2.4 \text{ [V]}$$

$$\text{Buck-boost to Boost} = V_{LED} \cong 1.11 \cdot V_{CC} + 1.34 \text{ [V]}$$

$$\text{Boost to Buck-Boost} = V_{LED} \cong 1.11 \cdot V_{CC} + 0.44 \text{ [V]}$$

Slope Compensation.

LX2260 operates in fixed frequency CCM mode. Therefore, in some conditions, the duty cycle may extend beyond 50%. This condition will cause sub-harmonic instability. The cure for this is adding an additional ramp current. An external resistor (minimum 100k Ω) will set the ramp current for the internal current slope compensation circuit.

Use the following equation to set the external resistor for the slope compensation:

$$R_{ICOMP} [k\Omega] \approx \frac{66.7 \cdot L [\mu H]}{R_{SENSE} [m\Omega]}$$

Start-up

The start-up or wake-up is controlled to minimize inrush or to eliminate the starting surge current required from the input power supply. EN pin input is always alive, therefore the LX2260 consumes a minimal amount of current even when the chip is in sleep mode (EN=low).

LX2260's start-up time is set by an external capacitor C_{CSS} , V_{LED} , the highest V_{DS} , and PWM duty cycle (D_{PWM}). During start-up, C_{CSS} is charged up at 120 μA until lowest VD reaches to 700mV. Use the following equation to estimate the start up T_{SU} where D_{PWM} is in decimal number.

$$T_{SU} [Sec] \approx \frac{C_{CSS} [\mu F] \cdot ((V_{LED} - 1) + V_{DS_MAX})}{120\mu A \cdot 20 \cdot D_{PWM}}$$

To speed up the startup time with low PWM duty cycle, user may try to stagger the PWM inputs so that the DC/DC converter stays active for an extended time. The LX2260's DC/DC converter is active when any of the active string's PWM inputs are high.

Over Current and Over Current Shutdown (OC SHDN).

In any mode of power conversion or any test condition, once over current (OC) is detected, the PDRV turns off for 4 switching clock cycles and then resumes operation. An internal 4 event counter accumulates the number of over current triggers that happen within 128 clock cycles. In other words, the 4 event counter is reset by 1/128 clock. At the 4th over current event (in case there is the 1/128 reset coming before the 4th trigger, total number of over current triggers that cause shutdown became more than 4), the chip shuts off the DC-DC converter and discharges CSS capacitor to 75mV. The chip resumes operation thereafter. If the over current condition is still present, the chip repeats the shut down and recovery cycle. The status of over current (OC) will set Bit 2 of register 07h to "1". Bit 2 will reset after reading.

THEORY OF OPERATION- CONTINUED
Over Temperature Protection (OTP).

In any mode of power conversion or any test condition, once over OTP is detected (typical is 150°C), the LX2260 will shutdown. The status of OTP will set Bit 1 of register 07h to “1”. Bit 1 will reset after reading in real time and OTP is low. System will resume operation when temperature drops below the shutdown recovery threshold voltage (typical is 130°C).

Temperature Warning (T_Warning).

In any mode of the converter or any test condition, once T_warning is detected (typical is 120°C), the status of T_warning will set Bit 0 of register 07h to “1”. Bit 1 will reset after reading in real time that T_Warning is low.

Fault Flags:

The following faults will set the FFLAG to “Low”, and be reset either by after reading via SMBus. The fault output is intended to stay low for an extended period after internal faults are cleared. The timer is 8mS typical with 100kΩ on FS pin.

Fault Condition	Register /Bit	Reset By	Notes
String over voltage	Register 05h & 06h, bit 2 & 5	Toggle EN or VCC	When VD >6.75V
String Open	Register 05h & 06h, bit 1 & 4	Toggle EN or VCC	When VD <0.2V
T-WARNING	Register 07h bit 0	After reading & real time T WARNING is Low	
OTP	Register 07h bit 1	After reading & real time OTP is Low	
OC	Register 07h bit 2	After reading & real time OC is Low	
OC SHDN	Register 07h bit 3	After reading & chip resumes start up	

5V Regulator

The 5V regulator generates 5V from VCC to the internal low voltage circuit and also provides power for an external light sensor (such as LX1973). Maximum output current is limited to 2mA for the external devices. The 5V output requires at least 0.1μF connected across VL pin and GND for phase compensation. A 1μF capacitor is recommended and should be placed near the VL and tied to the GND plane. The 5V is shut off while the chip is in sleep mode (EN = low).

VCC-5.25V Regulator

VCC-5.25V (VH) is a floating VSS for the low voltage circuits residing across VCC and VH. During start up, VH is turned on after VL gets ready.

POR

POR is cleared 100μS (typ.) after VH exceeds internal VH UVLO threshold.

LED Current Profiler

The OT input is a comparator with a threshold of 2V. It interfaces to an external NTC thermistor incorporated mechanically into the light bar or in close proximity to it. If the LED ambient temperature gets hot, the thermistor will sense it and decrease in resistance. This will in turn increase the OT pin voltage, and then the current sink will decrease the LED current in proportional with voltage at OT pin. The minimum of LED current when VOT reaches 4V is of 5% of LED current setting. If this feature is not used, then this pin should tie to GND.

If Minimum V_{DS} is more than 2V, then both PFET and NFET will be active to regulate LED current to minimum level.

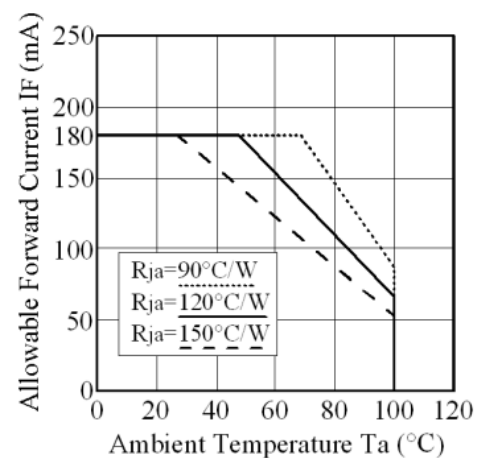

SOA of 180mA white LED from Nichia # NFSW036BT

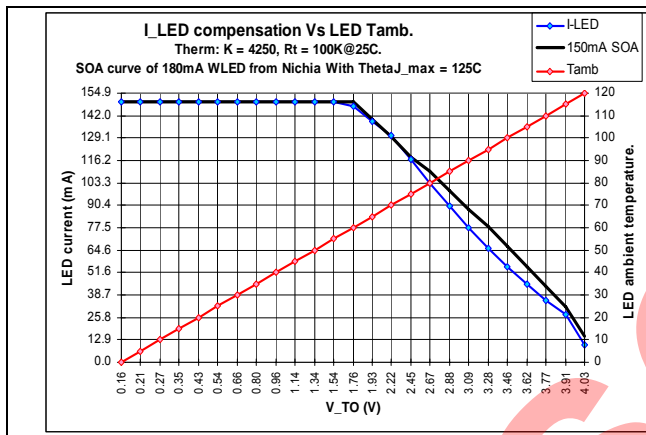
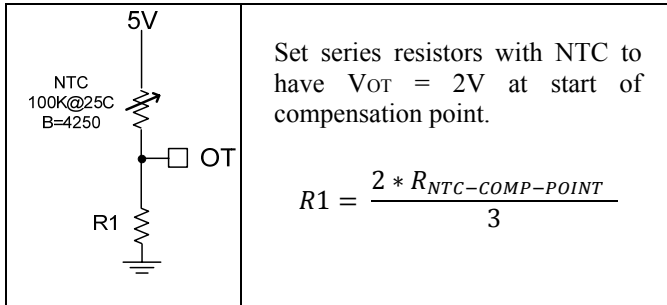
THEORY OF OPERATION- CONTINUED

PWM Dimming

The LED string currents are individual controlled directly by PWM input. A high on PWM input enables the output current.

DC Dimming (for application only)

DC dimming can be achieved, but not independently. In this mode, all the PWM inputs must be tied to VL, while the DC control signal goes to OT pin. The DC input range from 2V to 4V corresponding from 100% to 5% of LED current setting.

OVP

Two external resistors (R_{DOWN} & R_{UP}) program the LX2260's OVP level. The threshold is set to 2V (typical) at the OVP pin. When the OVP voltage threshold is reached it will stop the power converter from switching and then resume when the OVP pin voltage drops below the 2V threshold. The OVP function is active whenever the EN signal is high regardless the LED current condition.

$$OVP = \frac{2V * (R_{DOWN} + R_{UP})}{R_{DOWN}}$$

LED Open/Short Detection

In case a LED fails open or an opened string, the VD pin drops down to 0V. The power converter will try to raise the V_{LED} under this condition. The open string will then latch off when V_{LED} voltage reaches 100% of OVP setting. At latch off this string's VD pin voltage is excluded from the power supply regulation loop. The power converter will stop switching until the highest VD pin voltage drops below 2V and the OVP pin voltage is less than 2V. Any change in the V_{LED} voltage should have minimum impact to the LED output current since they are current source outputs. LED short protection is temporarily disabled when one or more open strings are detected. This allows VD to go beyond the LED short protection threshold of 7.25V (typ.). After successful latch off of any open string the VD voltage returns to a normal regulation level. The LX2260 reduces the LED current reference voltage to about 10% while $VD > 7.25V$ to avoid the external FET from overheating. The LED current returns to normal level when VD voltage gets below 7.25V. Cycling power or the EN input will reset any latched off VD pin.

User must tie VG pin to GND for any unused string to distinguish between string failed open and strings unused. In this situation any string that has VD higher than the LED short threshold voltage will not be latched off and not be reported with VD is higher than 6.75V.

The LED short fault is masked when any of VD is below open LED detection threshold until such string is latched off. Broken PWM input lines will be checked during start and reported as corresponding strings open

In case of the LED short condition, LX2260 output works normally until the VD voltage reaches the LED short threshold voltage, and the corresponding string is turned off. LED short protection works this way when there are more than two active strings and the lowest VD regulation is at normal level ($0.24V < VD < 2V$). This allows the VD voltage to go beyond the LED short threshold in case of an open string or temporary instability on VLED output. When there is only one active string in the system, the last string is latched off when VD voltage reaches to 7.25V. VD of the latched off strings are excluded from the power converter regulation loop.

Note: The size of NFET current sink must increase to handle LED short or VD voltages in excess of the LED short threshold voltage. Otherwise, the relative PWM input duty cycle must be reduced if smaller NFET is used.

THEORY OF OPERATION- CONTINUED
Current Source Driver

This is the current source driver for the external LED current sink NFET. The driver output VG_x, and the feedback signal IS_x will regulate the LED current through an internal op amp with a 300mV band gap (current source reference), for unused string will tie VG to ground. The lowest drain voltage of any external current sink NFET is used to regulate the boost, buck, or buck-boost voltage output. All the drains will report back to host computer through the SMBus to determine the strings status (number of shorted LED, open LED) The LED current matching between strings is 1.5% when matched with an external current sense resistor whose tolerance is 0.1% at room ambient temperature. The IC specifies voltage only at IS_x pin and the voltage matching is +/-1.5%.

$$LED_{CURRENT} [mA] = \frac{300mV}{R_{IS} [\Omega]}$$

Where R_{IS} tolerance must be 1% or less for better matching.

LED Output Current Rise/Fall Time Control

LX2260's LED output current rise/fall time can be programmed by one external resistor connected between SLOPE and GND.

Rise/Fall time can be calculated by:

$$R_{SLOPE} [k\Omega] = 20 * T_R \text{ OR } T_F [\mu S]$$

Recommended use 20kΩ and greater resistor.

Connect SLOPE pin to VL when slope control is not used. 5V on SLOPE pin selects an internal 20kΩ

For long cable from V_{LED} and V_{DS} to LED assembly, the minimum T_R and T_F must be selected based on wire inductance to minimize the LED current ringing.

$$T_R \text{ OR } T_F [\text{sec}] \geq 10 * L_{WIRE} [H] * I_{LED} [A]$$

Error Amplifier Compensation

R_{COMP_T}, R_{COMP_K}, and C_{COMP_x}, configure the error amplifier gain characteristics to accomplish a stable voltage loop gain. One advantage of current mode is the ability to close the loop with only two feedback components R_{COMP_x} and C_{COMP_x}. Additional, there is a right-half plane zero (RHPZ) associate with the modulator.

The lowest RHPZ occurs at minimum V_{IN} for Boost mode and is maximum V_{IN} for Buck/Boost mode at maximum load.

In boost mode, the components R_{COMP_T}, and C_{COMP_x} will be selected to set a zero about 30% of RHPZ frequency.

Where

$$F_{RHPZ} [Hz] = \frac{V_{IN}^2}{2\pi * I_{OUT} * L * V_{OUT}}$$

$$F_Z = \frac{1}{2\pi RC} \approx \frac{F_{ZRHPZ}}{3.3}$$

OR

$$R_{COMP_T} \approx \frac{3.3}{2\pi * C_{COMP_x} * F_{RHPZ}}$$

While R_{COMP_K} is for both Buck and Buck/Boost mode. Therefore, R_{COMP_K} must be selected to satisfy for both cases. In this case, the frequency of RHPZ of Buck/Boost is much higher than the desire Buck compensation network zero. Therefore,

$$R_{COMP_K} \approx \frac{250}{2\pi * C * F_{SW}}$$

Adjustment may have to be made to ensure stability in the actual circuitry.

Increasing R_{COMP_x} while proportionally decreasing C_{COMP_x} will yield higher error amplifier gain or vice versa.

For the design optimize, select C_{COMP_x} = 1nF.

For Boost design example with

$$\begin{aligned} V_{OUT} &= 25V, & V_{IN_MIN} &= 6V \\ I_{OUT} &= 0.6A, & L &= 15\mu H, \\ C_{COMP_x} &= 1nF, & F_{SW} &= 600Khz \end{aligned}$$

$$Boost_F_{RHPZ} = 25.5Khz$$

$$R_{COMP_T} \approx \frac{3.3}{2\pi C F_{RHPZ}} = 20.6K\Omega$$

And

$$R_{COMP_K} \approx \frac{250}{2\pi C F_{SW}} = 66.3K\Omega$$

Input Capacitors

Since the Vin pin is supply voltage for the IC. It is recommended to place a 4.7uF or higher with low ESR bypass capacitor. If the power source is long distance, then bulk parallel capacitors are needed to reduce input voltage ripple that may affect the transition mode voltage.

THEORY OF OPERATION- CONTINUED
Output Capacitors

The bulk parallel of capacitors are set to reduce the ripple due to charge into capacitors each cycle. The following formulae are use for Boost and Buck in steady state:

$$\%Ripple_Boost = \frac{I_{OUT-MAX} (V_{OUT} - V_{IN}) 100}{C_{OUT} * V_{OUT}^2 * F} \%$$

$$\%Ripple_BUCK = \frac{I_{OUT-MAX} (V_{IN-MAX} - V_{OUT}) 100}{C_{OUT} * V_{IN-MAX} * V_{OUT} * F} \%$$

Where

C_{OUT} = Output capacitor in Farad

F = Switching frequency in Hz

To handle the transient response of the converter, the output capacitors is usually larger than the calculation.

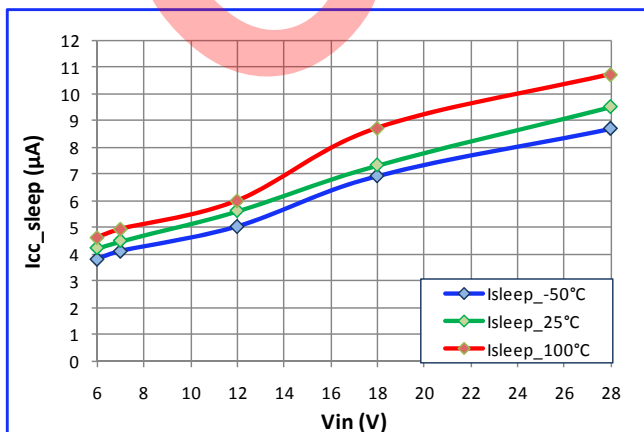
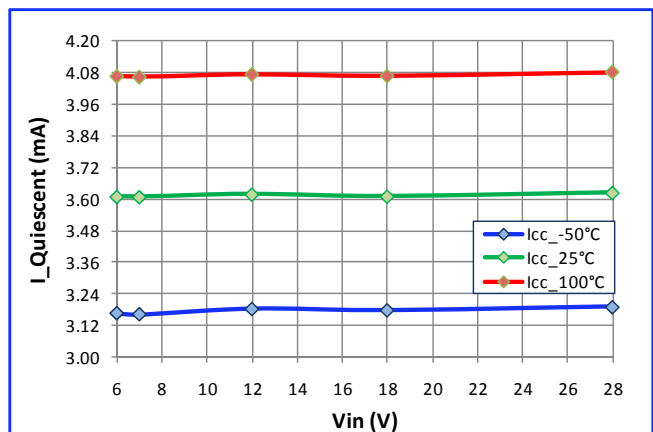
Typical Operating Characteristics
SLEEP CURRENT VS. V_{IN}

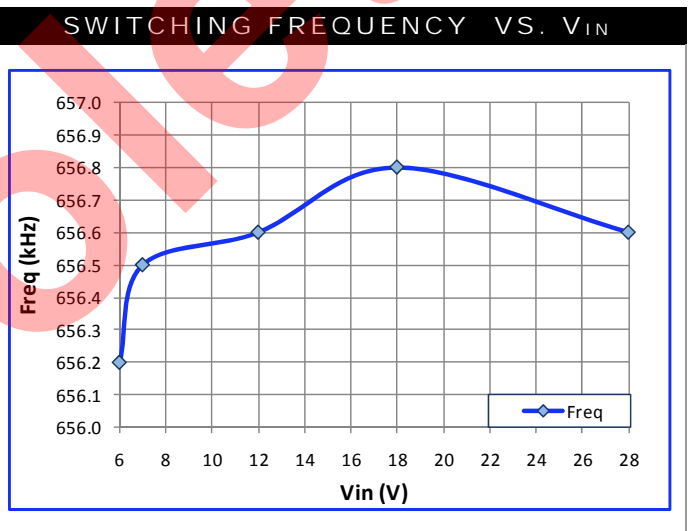
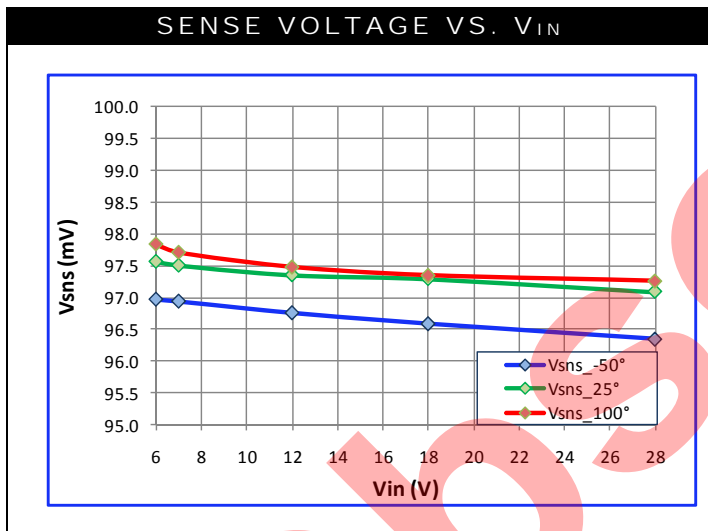
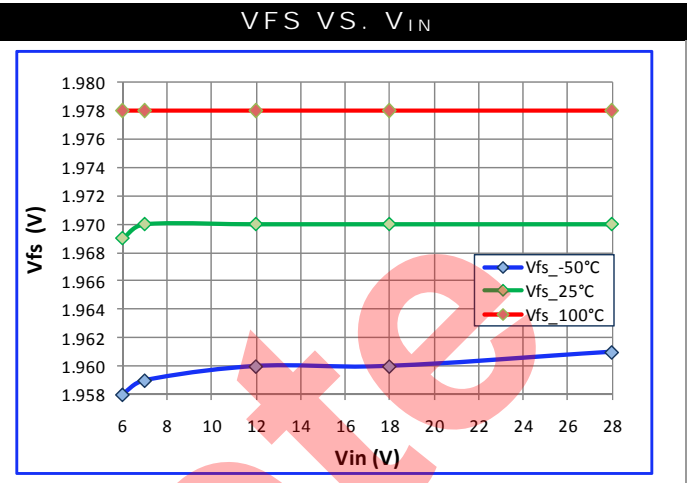
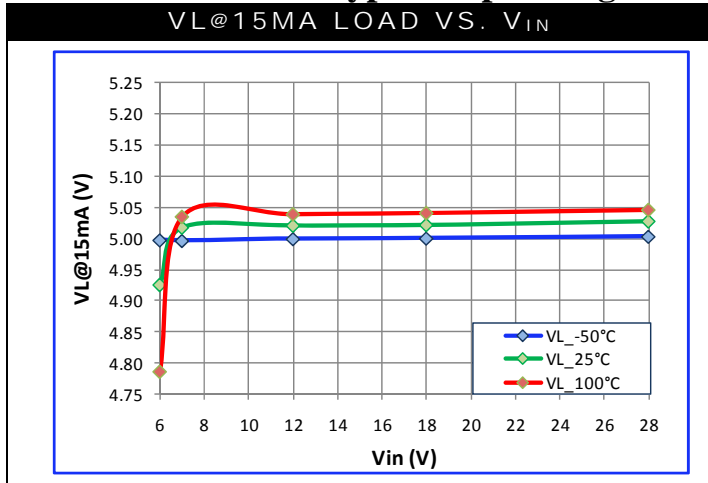
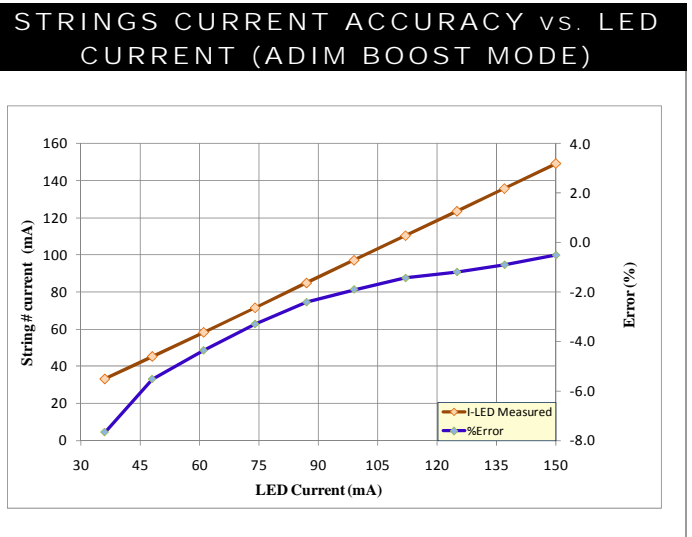
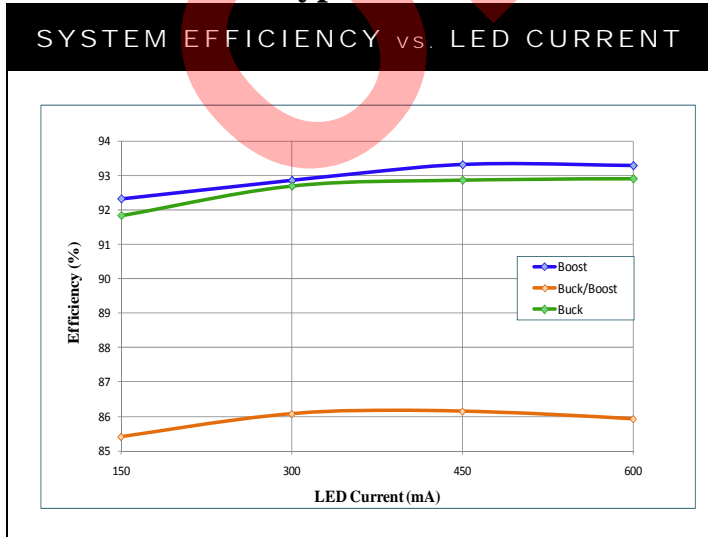
QUIESCENT CURRENT VS. V_{IN}

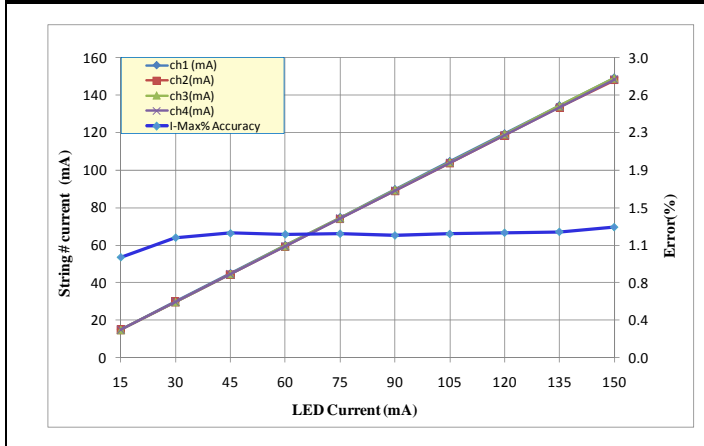
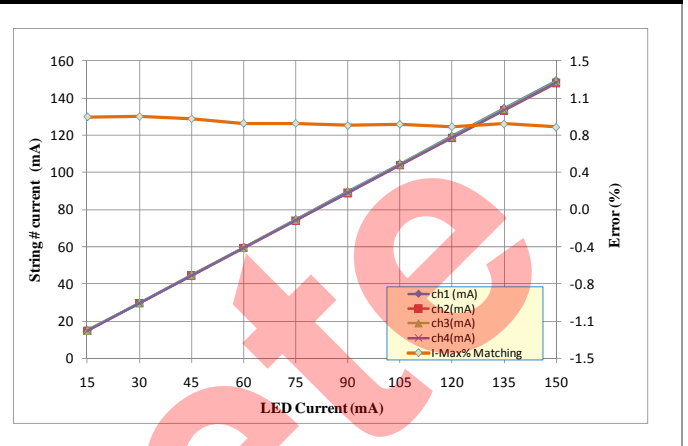
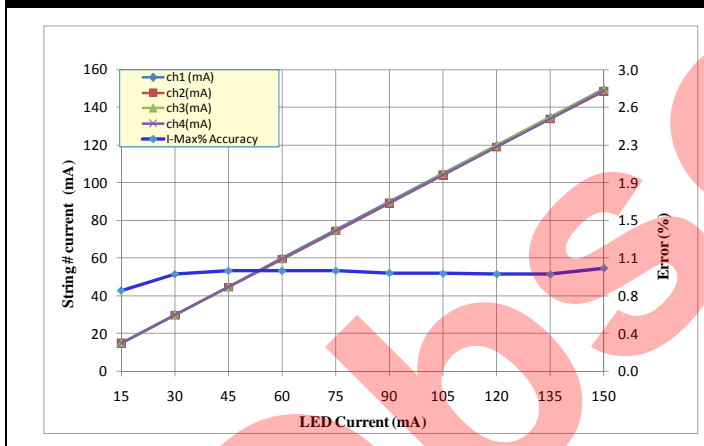
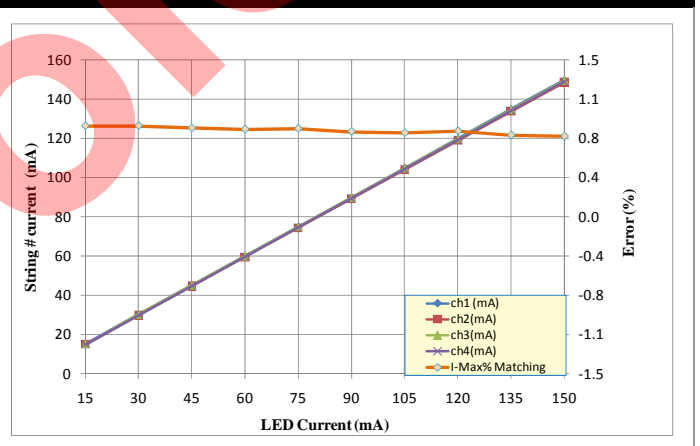
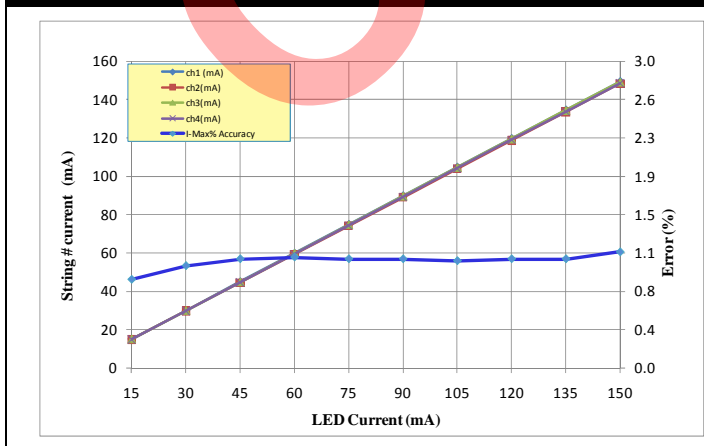
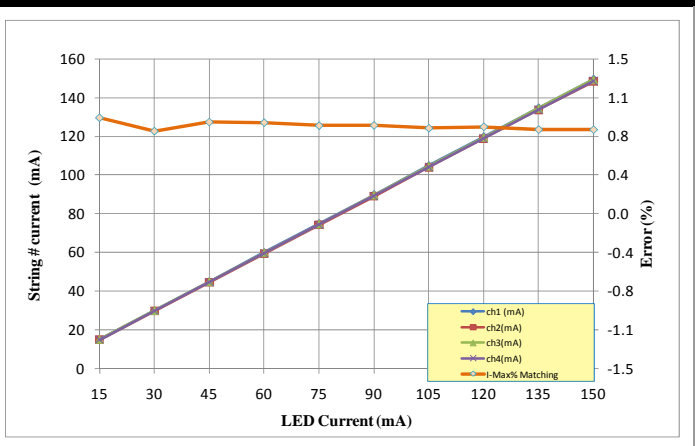
Typical Operating Characteristics - continued

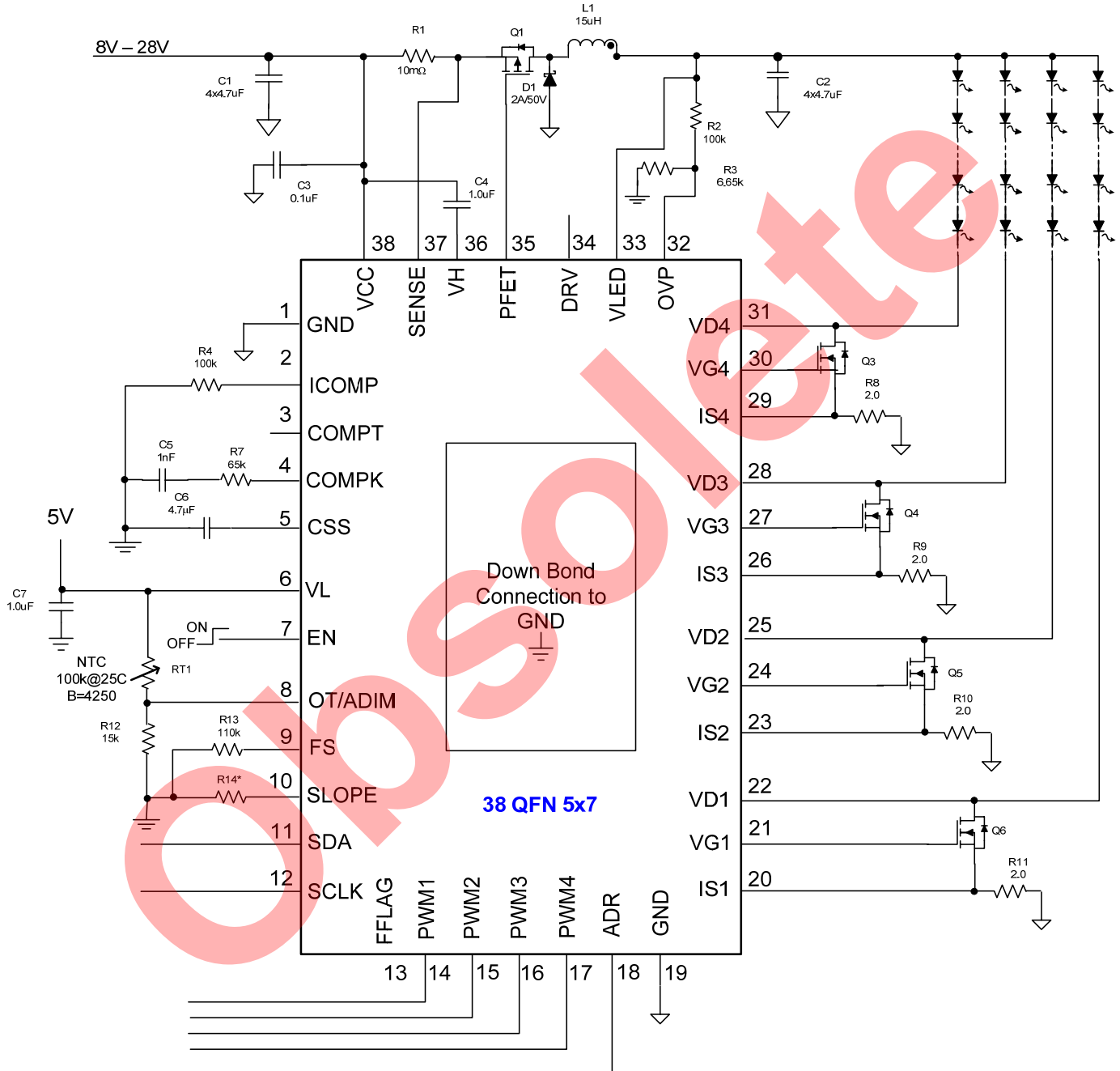
Typical Characteristics @ 25°C and 5 LED in Series

Typical Characteristics @ 25°C and 5 LED in Series - continued
STRINGS CURRENT ACCURACY vs. LED CURRENT (BOOST MODE)

STRINGS CURRENT MATCHING vs. LED CURRENT (BOOST MODE)

STRINGS CURRENT ACCURACY vs. LED CURRENT (BUCK/BOOST MODE)

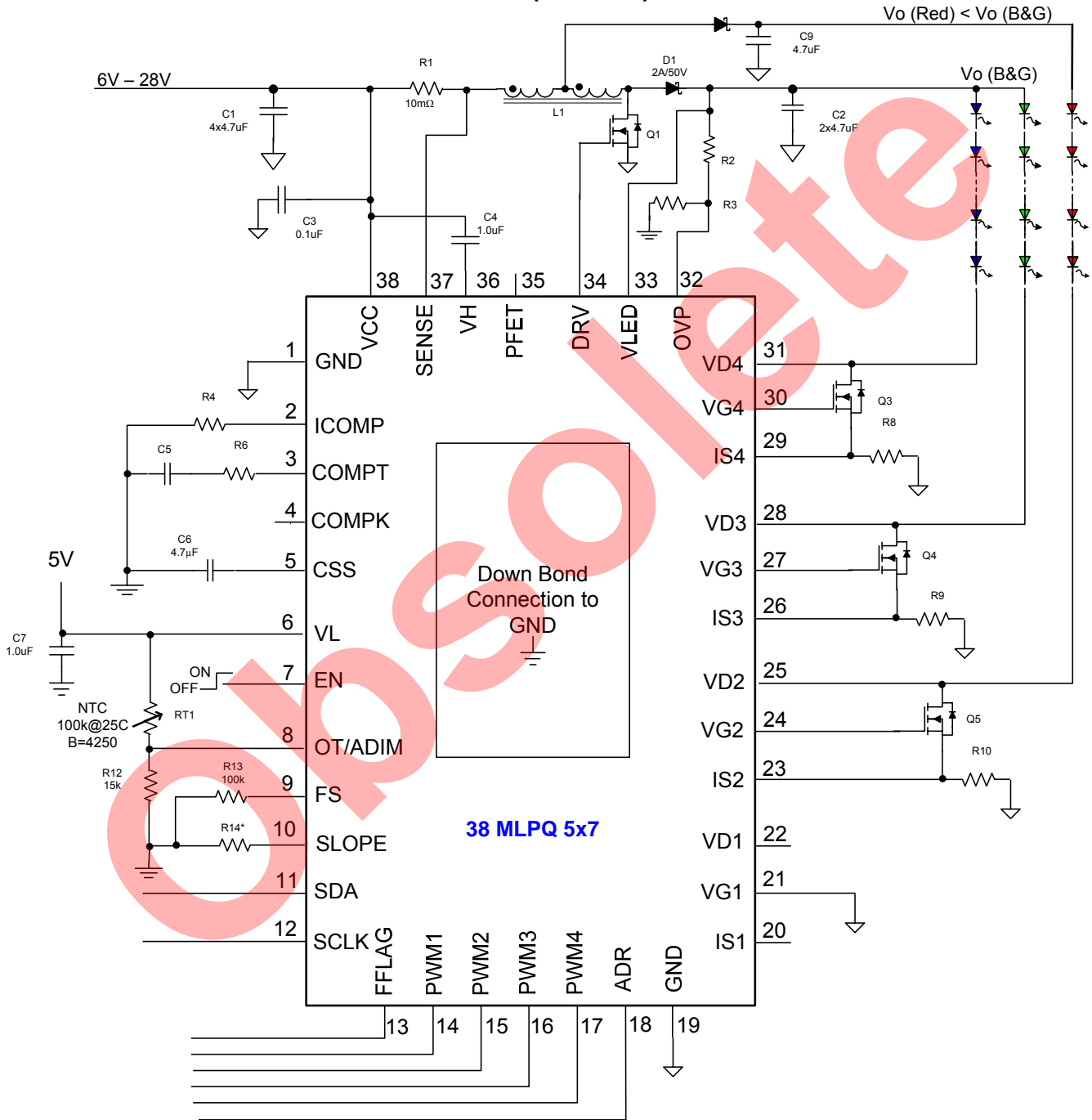
STRINGS CURRENT MATCHING vs. LED CURRENT (BUCK/BOOST MODE)

STRING CURRENT ACCURACY vs. LED CURRENT (BUCK)

STRING CURRENT MATCHING vs. LED CURRENT (BUCK)

TYPICAL APPLICATION CIRCUITS
Buck Mode Converter ($V_{IN} > V_O$)

The component values are for reference only

Note: A resettable fuse at V_{IN} is needed for protection when output short to ground occurs.

TYPICAL APPLICATION CIRCUITS
Boost Mode Converter ($V_{in} < V_o$) for RGB LEDs

The component values are for reference only

PCB LAYOUT GUIDELINES

1. The Input power filter capacitors for the converter, they need to tie to power ground plane (PGND)
2. The input current sense must use Kevin trace directly from sense resistor to SENSE pin. The same method for VLED, it must be connected at the output capacitors.
3. The coupling capacitor for VL must be closed to VL pin.
4. All switching NFET, PFET, inductor, current sense resistor, and rectifier diodes must be closed together with heavy traces to have small power return loop to minimize switching noise.
5. Place all compensation components close to their pins possible.
6. Analog ground and power ground tie to a point at IC case ground
7. **All the ground side of sense resistors who connect to ISx pin must be tie together to a point before tie to ground pin (pin19) as shown below.**
8. Refer to LX2260EV3 board for an example of proper board layout.

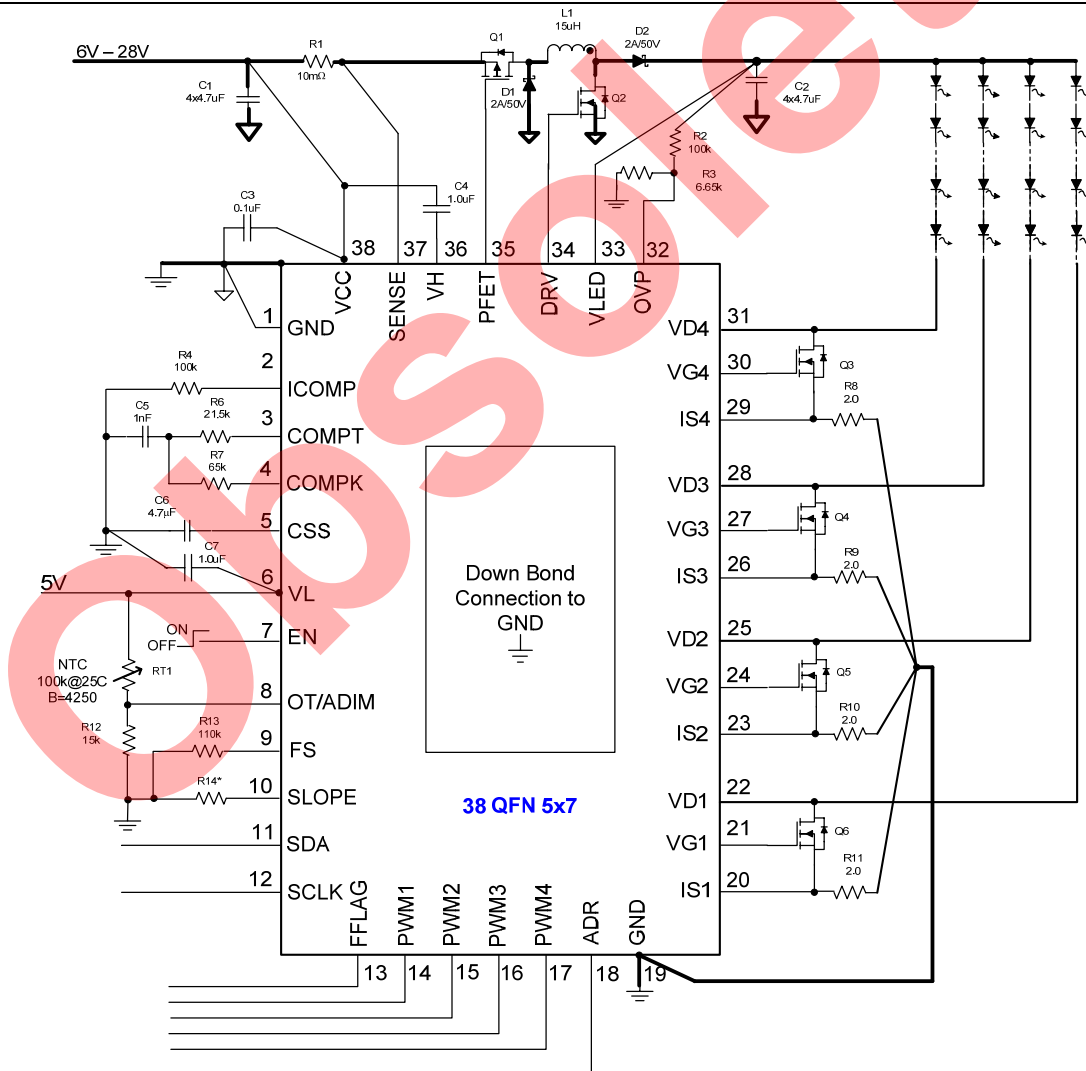

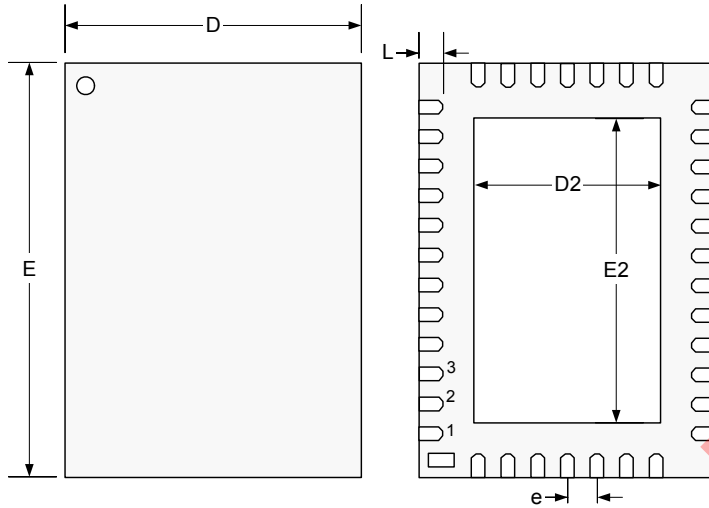
PACKAGE DIMENSIONS
LQ 38-Pin Plastic QFN (5x7mm) Exposed Pad

Dim	MILLIMETERS		INCHES	
	MIN	MAX	MIN	MAX
A	0.80	1.00	0.031	0.039
A1	0	0.05	0	0.002
A3	0.20 REF		0.008 REF	
b	0.18	0.30	0.007	0.011
D	5.00 BSC		0.196 BSC	
D2	3.00	3.25	0.118	0.127
E	7.00 BSC		0.275 BSC	
E2	5.00	5.25	0.196	0.206
e	0.50 BSC		0.019 BSC	
L	0.30	0.50	0.012	0.020

Note:

1. Dimensions do not include mold flash or protrusions; these shall not exceed 0.155mm(.006") on any side. Lead dimension shall not include solder coverage

PRODUCTION DATA – Information contained in this document is proprietary to Microsemi and is current as of publication date. This document may not be modified in any way without the express written consent of Microsemi. Product processing does not necessarily include testing of all parameters. Microsemi reserves the right to change the configuration and performance of the product and to discontinue product at any time.