

MC33690

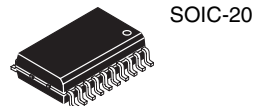

MC33690 Standalone Tag Reader Circuit

The standalone tag reader circuit (STARC) is an integrated circuit dedicated to the automotive immobilizer applications. It combines the antenna drivers and demodulator necessary to interface with a transponder.

A low dropout voltage regulator and a physical interface fully compatible with the ISO 9141 norm are also available.

The STARC is fabricated with the SMARTMOSTM3.5 technology. This process is a double layer metal 1.4µm 45V technology, combining CMOS and bipolar devices.

- Contactless 125 kHz tag reader module:
 - Self synchronous sample and hold demodulator
 - Amplitude or phase modulation detection
 - High sensitivity
 - Fast read after write demodulator settling time
 - Low resistance and high current antenna drivers, 2W @ 150mA (typ.)
 - Bidirectionnal data transmission
 - Multi-tag, multi-scheme operation
- Low dropout voltage regulator:
 - Wide input supply voltage range from 5.5V up to 40V
 - Output current capability up to 150mA DC with an external power transistor
 - 5V output voltage with a ±5% accuracy
 - Low voltage reset function
 - Low current consumption in standby mode:
 - 300µA (typ.)
- ISO 9141 transmitter and receiver module:
 - Input voltage thresholds ratiometric to the supply voltage
 - Current limitation
 - Output slew rate control
 - No external protection device required

Pin Connections

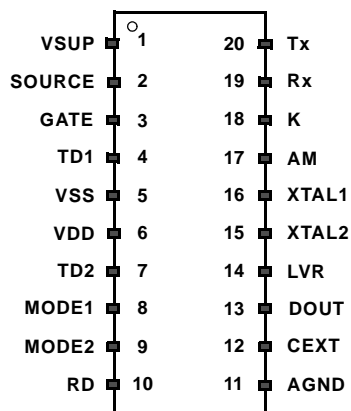

ORDERING INFORMATION

Device	Operating Junction Temperature Range	Package
MC33690DW	T _J = -40°C to 125°C	SOIC 20
MC33690DWE	T _J = -40°C to 125°C	SOIC 20 (ROHS)

This document contains information on a product under development. Freescale reserves the right to change or discontinue this product without notice.

Table of Contents

1	Description	5
1.1	Tag Reader Module	5
2	Read Function	6
3	Write Function	7
4	Voltage Regulator	7
5	ISO 9141 Physical Interface	8
6	Communication Modes Description	9
7	Standalone Configuration with One-Wire Bus	10
7.1	Timing Definitions for a 8 MHz Crystal	11
8	Standalone Configuration with Two-Wire Bus	12
9	Direct Connection to a Microcontroller Configuration	13
10	Electrical Characteristics	13
11	Supply Current	13
12	Voltage Regulator	14
13	Low-Voltage Reset	14
14	Oscillator	15
15	Tag Reader	16
16	ISO 9141 Interface	17
17	Digital I/O	18
18	Pin Definition and Function	19
19	Application Schemes	23

List of Figures

Figure 1.	Standalone Tag Reader Circuit	3
Figure 2.	Tag Reader Block Diagram	6
Figure 3.	Current Flow When Buffers are Switched Off	7
Figure 4.	Voltage Regulator Block Diagram	8
Figure 5.	ISO 9141 Interface	9
Figure 6.	Mode Access Description in One-Wire Bus Configuration	11
Figure 7.	Configuration A State Diagram	11

Figure 8.	Modes Access Description in Two-wire Bus Configuration	12
Figure 9.	Configuration B State Diagram	12
Figure 10.	Configuration C State Diagram	13
Figure 11.	Low Voltage Reset Waveform	15
Figure 12.	Demodulator Parameters Definition	17
Figure 13.	VSUP, VDD, and Source Internal Circuits	19
Figure 14.	GATE Internal Circuits	19
Figure 15.	TD1, TD2, DOUT, and RX Internal Circuits	19
Figure 16.	AGND Internal Circuits	20
Figure 17.	CEXT Internal Circuits	20
Figure 18.	RD Internal Circuits	20
Figure 19.	MODE1, MODE2, and TX Internal Circuits	20
Figure 20.	LVR Internal Circuits	21
Figure 21.	XTAL2 and XTAL1 Internal Circuits	21
Figure 22.	AM Internal Circuits	22
Figure 23.	K Internal Circuits	22
Figure 24.	Standalone Configuration with One-Wire Bus	23
Figure 25.	Standalone Configuration with Two-Wires Bus	24
Figure 26.	Direct Connection to a Microcontroller	25

List of Tables

Table 1.	Maximum Ratings	4
Table 2.	Thermal Characteristics	4
Table 3.	Pin Function Descriptions	4
Table 4.	Communication Modes Description	10
Table 5.	Supply Current Specifications	14
Table 6.	Voltage Regulator Specifications	14
Table 7.	Low-Voltage Reset Specifications	15
Table 8.	Oscillator Specifications	15
Table 9.	Tag Reader Specifications	16
Table 10.	ISO 9141 Interface Specifications	17
Table 11.	Digital I/O Specifications	18

Optional: External N channel MOS required for sourced current > 50mA.
 A recommended reference is MMFT 3055VL from Freescale.

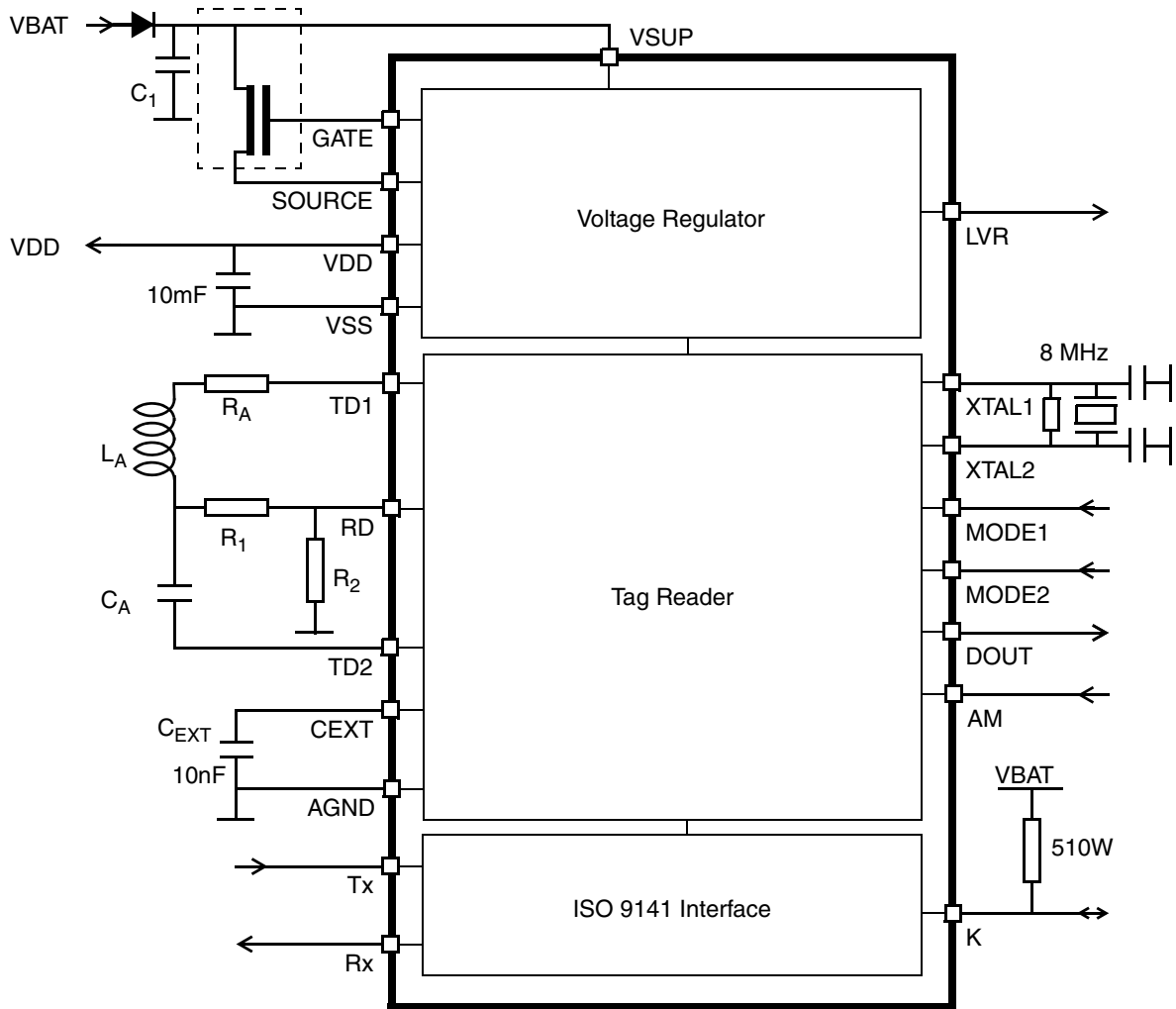

Figure 1. Standalone Tag Reader Circuit

Table 1. Maximum Ratings

Rating	Symbol	Value	Unit
Supply voltage	V_{SUP}	$V_{SS} - 0.3$ to +40	V
Supply voltage without using the voltage regulator ($V_{SUP} = V_{DD}$)	V_{DD}	$V_{SS} - 0.3$ to +7	V
Voltage on SOURCE	—	$V_{SS} - 0.3$ to +40	V
Current into/from GATE	—	0	mA
Voltage on GATE	—	$V_{SS} - 0.3$	V
Voltage on pins: MODE1/2, CEXT, DOUT, LVR, XTAL1/2, Rx, Tx	—	$V_{SS} - 0.3$ to $V_{DD} + 0.3$	V
Voltage on RD	—	± 10	V
Voltage on K and AM	—	$V_{SS} - 3$ to 40	V
Current on TD1 and TD2 (Drivers on and off)	—	± 300	mA
Voltage on AGND	—	$V_{SS} \pm 0.3$	V
ESD voltage capability ¹	—	± 2000	V
ESD voltage capability ¹	—	± 200	V
Solder heat resistance test (10s)	—	260	°C
Junction temperature	T_J	170	°C
Storage temperature	T_s	-65 to +150	°C

¹ Human Body Model, AEC-Q100-002 Rev. C; Machine Model, AEC-Q100-003 Rev. E.

Table 2. Thermal Characteristics

Characteristic	Symbol	Value	Unit
Junction to ambient thermal resistance (SOIC20)	R_{th}	80	°C/W

Table 3. Pin Function Descriptions

Pin	Function	Description
1	VSUP	Power supply
2	SOURCE	External N channel transistor source
3	GATE	External N channel transistor gate
4	TD1	Antenna driver 1 output
5	VSS	Power and digital ground
6	VDD	Voltage regulator output
7	TD2	Antenna driver 2 output
8	MODE1	Mode selection input 1
9	MODE2	Mode selection input 2
10	RD	Demodulator input

Table 3. Pin Function Descriptions (continued)

11	AGND	Demodulator ground
12	CEXT	Comparator reference input
13	DOUT	Demodulator output (5V)
14	LVR	Low Voltage Reset input/output
15	XTAL2	Oscillator output
16	XTAL1	Oscillator input
17	AM	Amplitude modulation input
18	K	ISO 9141 transmitter output and receiver input
19	Rx	ISO 9141 receiver monitor output
20	Tx	ISO 9141 transmitter input

1 Description

1.1 Tag Reader Module

The tag reader module is dedicated for automotive or industrial applications where information has to be transmitted contactless. The tag reader module is a write/read (challenge/response) controller for applications that demand high security level.

The tag reader module is connected to a serial-tuned LC circuit that generates a magnetic field power supplying the tag. The use of a synchronous sample and hold technique allows communication with all available tags using admittance switching producing absorption of the RF field.

Load amplitude or phase shift modulation can be detected at high bit rates up to 8 kHz. The typical operational carrier frequency of the tag reader module with an 8 MHz clock is 125 kHz.

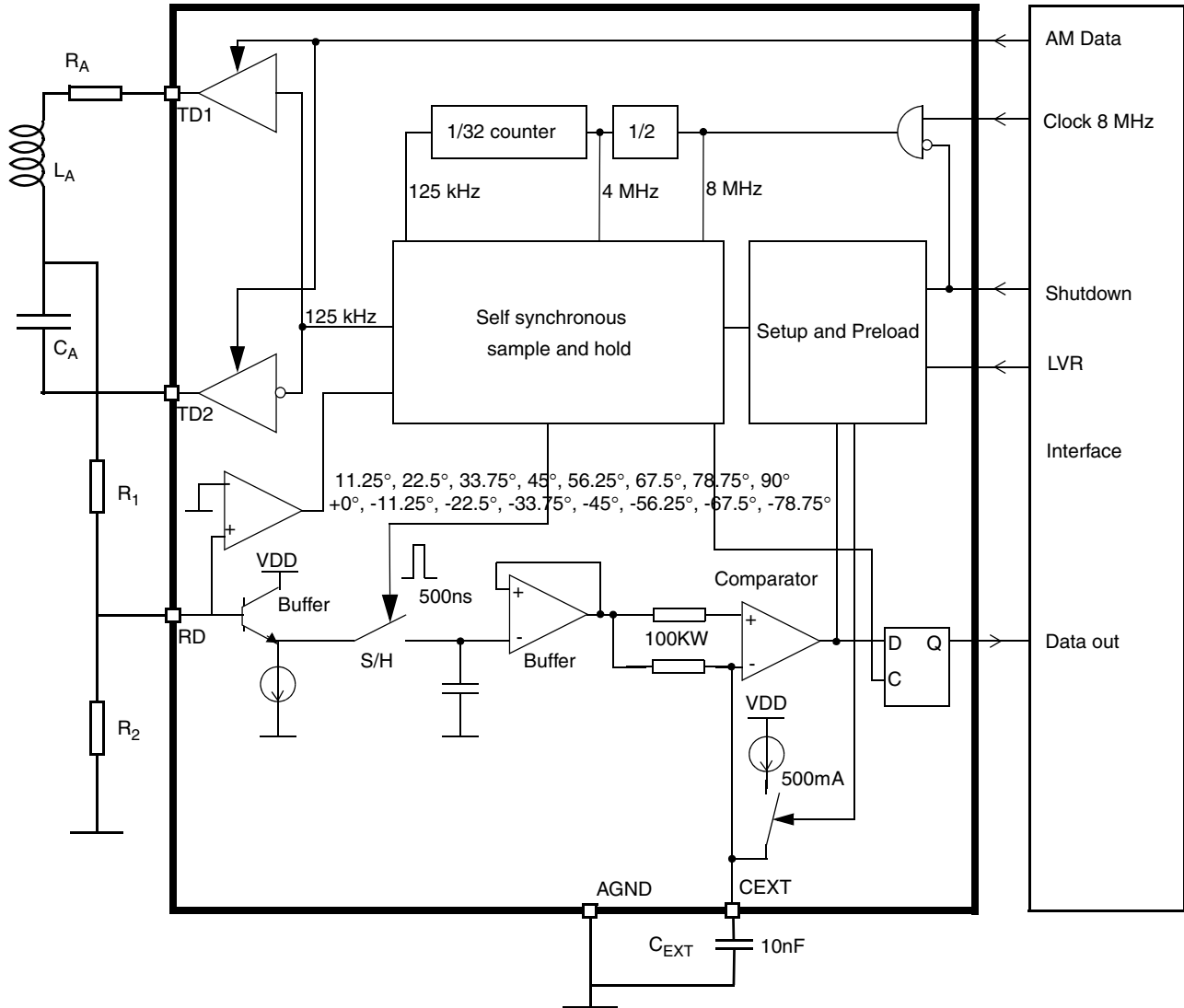

Figure 2. Tag Reader Block Diagram

2 Read Function

When answering to the base station, a transponder generates an absorption modulation of the magnetic field. It results in an amplitude/phase modulation of the current across the antenna. This information is picked up at the antenna tap point between the coil and the capacitor. An external resistive ladder down scales this voltage to a level compatible with the demodulator input voltage range (see Section 15, “Tag Reader”).

The demodulator (see Figure 2) consists of:

- an input stage (emitter follower)
- a sample and hold circuit
- a voltage follower
- a low offset voltage comparator

The sampling time is automatically set to take into account a phase shift due to the tolerances of the antenna components (L and C) and of the oscillator. The allowed phase shift measured at the input RD ranges from -45° to $+45^\circ$. Assuming that the phase

reference is the falling edge of the driving signal TD1, this leads to a sampling time phase ranging from -78.75° to 90° with discrete steps of 11.25° . After reset condition, the sampling time phase is $+11.25^\circ$.

The antenna phase shift evaluation is only done after each wake-up command or after reset. This is necessary to obtain the best demodulator performances.

To ensure a fast demodulator settling time after wake-up, reset, or a write sequence, the external capacitor CEXT is preloaded at its working voltage. This preset occurs $256\mu\text{s}$ after switching the antenna drivers on and its duration is $128\mu\text{s}$. After wake-up or reset, the preset has the same duration, but begins $518\mu\text{s}$ after clock settling. After power on reset, VSUP must meet the minimum specified value, enabling the nominal operation of VDD, before the start of the preset. Otherwise, the preset must be done through a standby/wake-up sequence.

3 Write Function

Whatever the selected configuration (see Section 6, “Communication Modes Description”), the write function is achieved by switching on/off the output drivers TD1/2. After the drivers have been set in high impedance, the load current flows alternatively through the internal diodes to VSS and to VDD (see Figure 3).

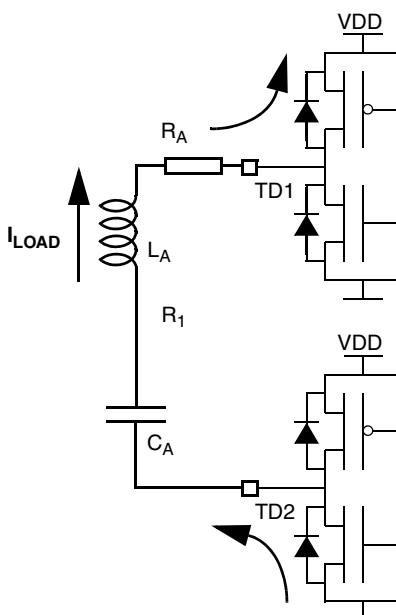

Figure 3. Current Flow When Buffers are Switched Off

4 Voltage Regulator

The low dropout voltage regulator provides a regulated 5V supply for the internal circuitry. It can also supply external peripherals or sensors. The input supply voltage ranges from 5.5V to over 40V.

This voltage regulator uses a series combination of high voltage LDMOS and low voltage PMOS transistors to provide regulation. An external low ESR capacitor is required for the regulator stability.

The maximum average current is limited by the power dissipation capability of the SO 20 package. This limitation can be overcome by connecting an external N channel MOS parallel with the internal LDMOS. The threshold voltage of this transistor must be lower than the one of the internal LDMOS (1.95V typ.) to prevent the current from flowing into the LDMOS. Its breakdown voltage must be higher than the maximum supply voltage.

A low-voltage reset function monitors the VDD output. An internal $10\mu\text{A}$ pull-up current source allows, when an external capacitor is connected between LVR and GND, to generate delays at power up (5ms typ. with $C_{Reset}=22\text{nF}$). The LVR pin is

ISO 9141 Physical Interface

also the input generating the internal reset signal. Applying a logic low level on this pin resets the circuit, all the internal flip flops are reset, and drivers TD1/2 are switched on.

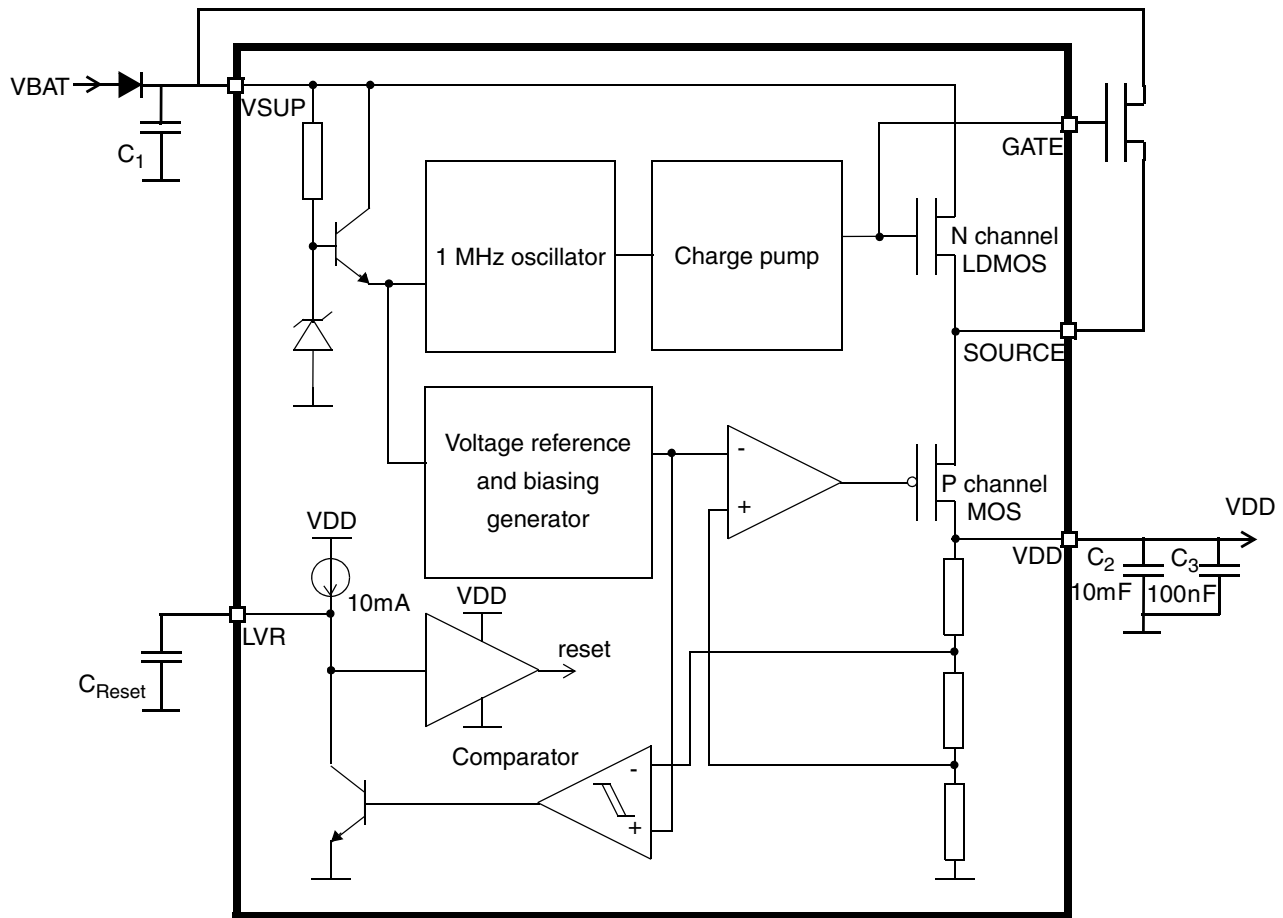

Figure 4. Voltage Regulator Block Diagram

5 ISO 9141 Physical Interface

This interface module is fully compatible with the ISO 9141 norm describing the diagnosis line. It includes one transmitter (pin K) and two receivers (pins K and AM).

The input stages consist of high-voltage CMOS triggers. The thresholds are ratiometric to VSUP. A ground referenced current source (2.5 μ A typ.) pulls down the input when unconnected.

When a negative voltage is applied on the K or AM lines, the input current is internally limited by a 2k Ω resistor (typ.) in series with a diode.

A current limitation allows the transmitter to drive any capacitive load and protects against short circuit to the battery voltage. An overtemperature protection shuts the driver down when the junction temperature exceeds 150 $^{\circ}$ C (typ). After shutdown by the overtemperature protection, the driver can be switched on again if the junction temperature has decreased below the threshold and by applying an off/on command, coming from the demodulator in configurations A and B, or directly applied on the input Tx in configuration C (see [Table 4](#)).

The electromagnetic emission is reduced because of the voltage slew rate control (5V/ μ s typ.).

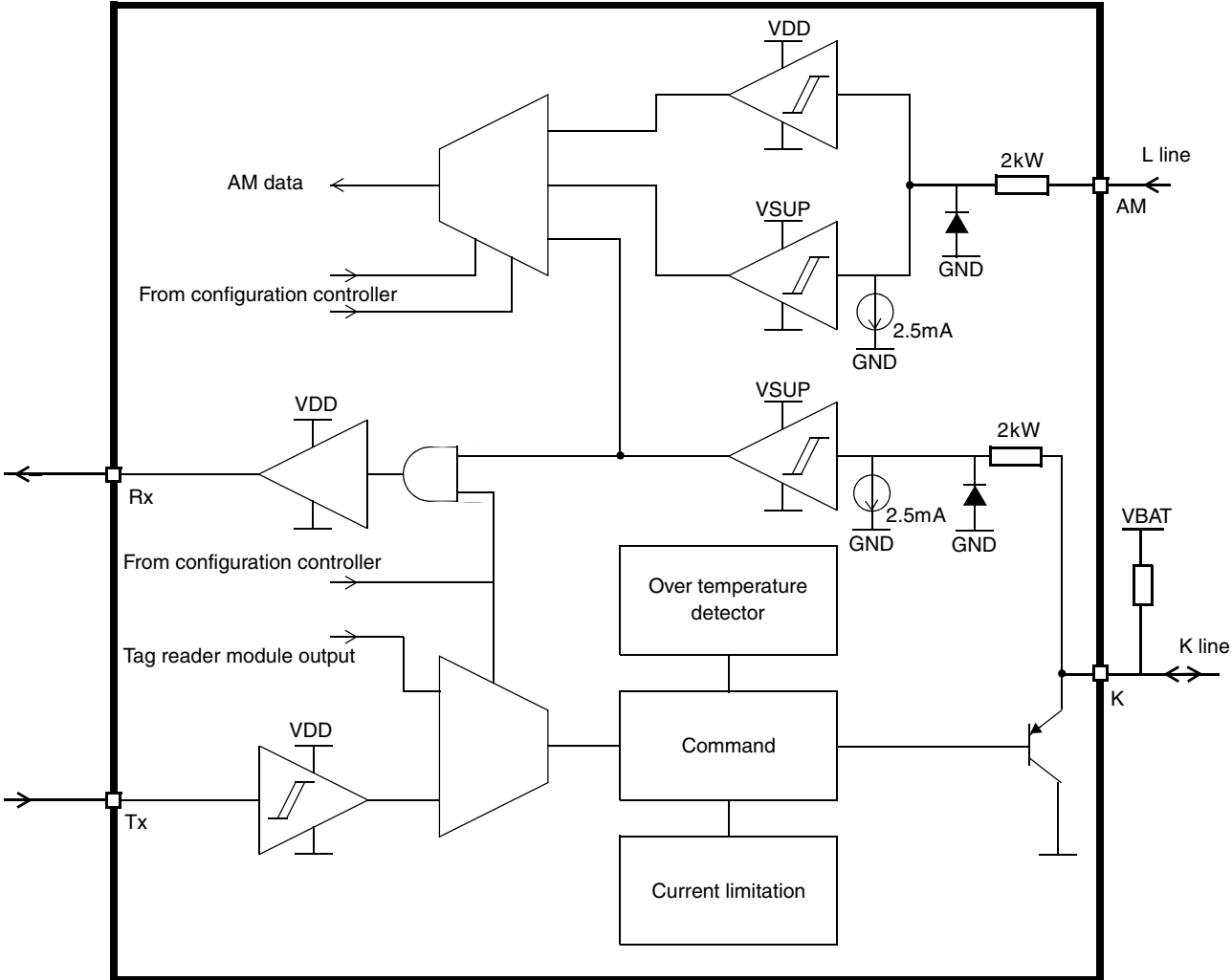

Figure 5. ISO 9141 Interface

6 Communication Modes Description

The STARC offers three different communication modes. Therefore, it can be used as a standalone circuit connected to an electronic control unit (ECU) through a bus line or it can be directly connected to a microcontroller in case of a single board architecture.

Table 4. Communication Modes Description

Configuration			Configuration Pins		Pin Status Function Description
Type	Bus Type	Name	Mode1	Mode2	
Standalone	1 wire (VBAT)	A	0	0	K output/input: <ul style="list-style-type: none"> • demodulator output • amplitude modulation input • shutdown/wake-up AM must be connected to VSUP DOUT forces a low level
	2 wires (VBAT)	B	0	1	K output: <ul style="list-style-type: none"> • demodulator output AM input: <ul style="list-style-type: none"> • amplitude modulation input • shutdown/wake-up DOUT forces a low level
Direct Connection to a MCU	2 wires (VDD)	C	1	x	DOUT output: <ul style="list-style-type: none"> • demodulator output AM input: <ul style="list-style-type: none"> • amplitude modulation input MODE2 input: <ul style="list-style-type: none"> • shutdown/wake-up
				1	K output/input (standalone ISO 9141 interface): <ul style="list-style-type: none"> • driven by Tx and monitored by Rx
				0	K input (standalone ISO 9141 interface): <ul style="list-style-type: none"> • monitored by Rx • Tx disabled

7 Standalone Configuration with One-Wire Bus

When a low level is applied on pins MODE1 and MODE2, the circuit is in configuration A (see [Figure 24](#)). After power on, the circuit is set into read mode. The demodulator output is directly routed to the ISO 9141 interface output K.

The circuit can be set into write mode at anytime by violation of all possible patterns on the single wire bus during more than 1ms. Then, the K line achieves the amplitude modulation by switching on/off both antenna drivers.

After 1ms of inactivity at the end of the challenge phase (bus in idle recessive one state), the circuit is set back into read mode.

The circuit can be put into standby mode by forcing the K line at zero during more than 2 ms after entering the write mode. After the K line is released, the circuit sends an acknowledge pulse before entering into standby mode. In standby mode, the oscillator and most of the internal biasing currents are switched off. Therefore, the functions (tag reader, ISO 9141 driver) are inactive except the voltage regulator and the ISO 9141 receiver on pin K. The driver output TD1 forces a low level and TD2 forces a high level. A rising edge on K wakes up the circuit. After completion of the wake-up sequence, the circuit is automatically set in read mode.

In configuration A, DOUT and Rx outputs always force a low level and Tx is disabled.

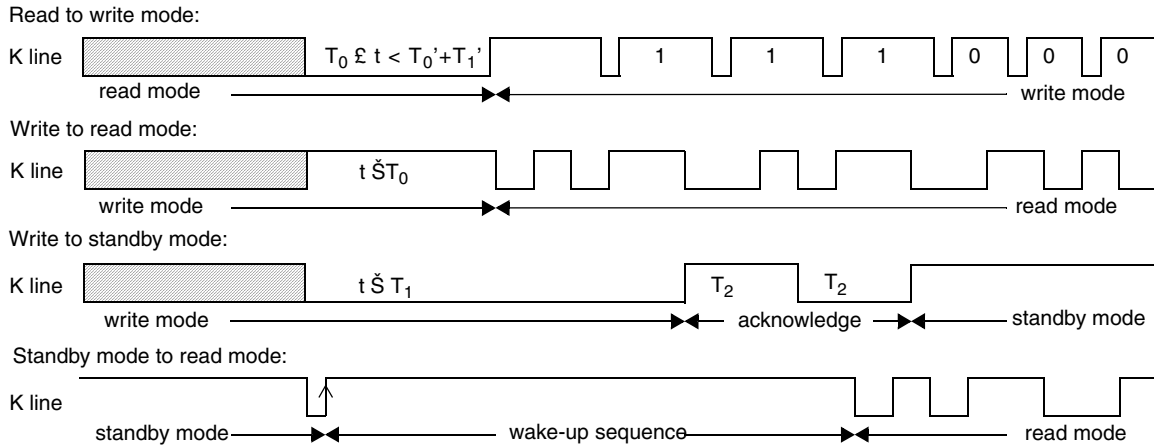

Figure 6. Mode Access Description in One-Wire Bus Configuration

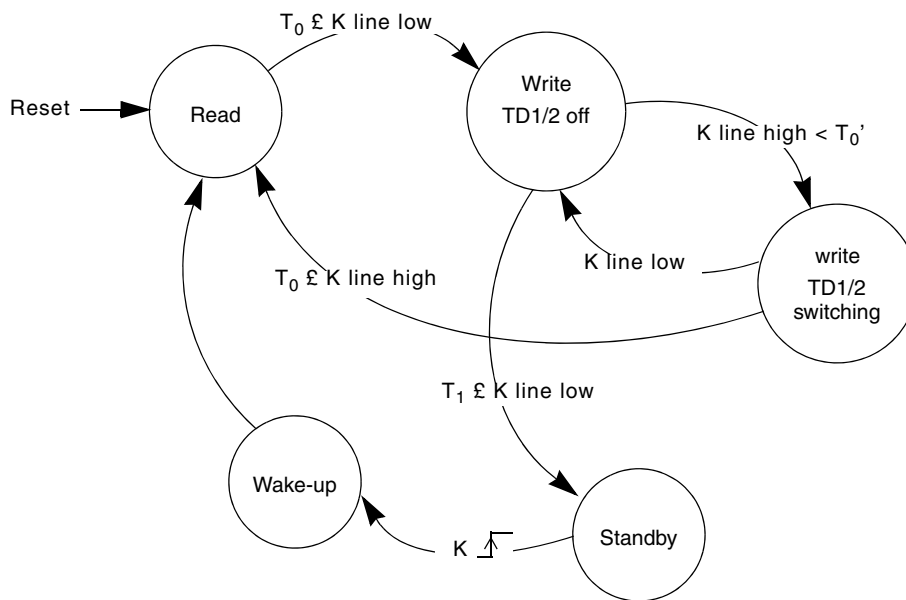

Figure 7. Configuration A State Diagram

7.1 Timing Definitions for a 8 MHz Crystal

The timing definitions for a 8 MHz crystal are:

- T_{ref} is crystal oscillator period (125 ns typ.)
- $T_0 = 8064 \cdot T_{ref} = 1.008\text{ms}$ typ.
- $T_0' = 7932 \cdot T_{ref} = 0.992\text{ms}$ typ.
- $T_1 = 16256 \cdot T_{ref} = 2.032\text{ms}$ typ.
- $T_1' = 16128 \cdot T_{ref} = 2.016\text{ms}$ typ.
- $T_2 = 4096 \cdot T_{ref} = 512\mu\text{s}$ typ.

T_0 is the minimum time required to guarantee the device toggles from read to write (or from write to read). However, the STARC may toggle from read to write (or from write to read) between T_0 and T_0' .

T_1 is the minimum time required to guarantee the device toggles from write to standby. However, the STARC may toggle in standby between T_1 and T_1' .

8 Standalone Configuration with Two-Wire Bus

When a low level is applied on MODE1 and a high level on MODE2, the circuit is in configuration B (see Figure 25). The K pin is set as an output sending the demodulated data.

The AM pin is set as a VSUP referenced input pin receiving the amplitude modulation and the shutdown/wake-up commands. Forcing high and low levels on AM achieves the amplitude modulation by switching on/off both antenna drivers. This amplitude modulation can be monitored on the K output and allows antenna short and open circuit diagnosis. The circuit can be put into standby mode by forcing the AM line at zero during more than 2 ms. The circuit sends an acknowledge pulse before entering into standby mode.

In standby mode, the oscillator and most of the internal biasing currents are switched off. Therefore, the functions (tag reader and ISO 9141 driver) are inactive except for the voltage regulator and the ISO 9141 receiver on pin AM. The driver output TD1 forces a low level and TD2 a high level. A rising edge on AM wakes up the circuit. After completion of the wake-up sequence, the circuit is automatically set in read mode.

In configuration B, DOUT and Rx outputs always force a low level and Tx is disabled.

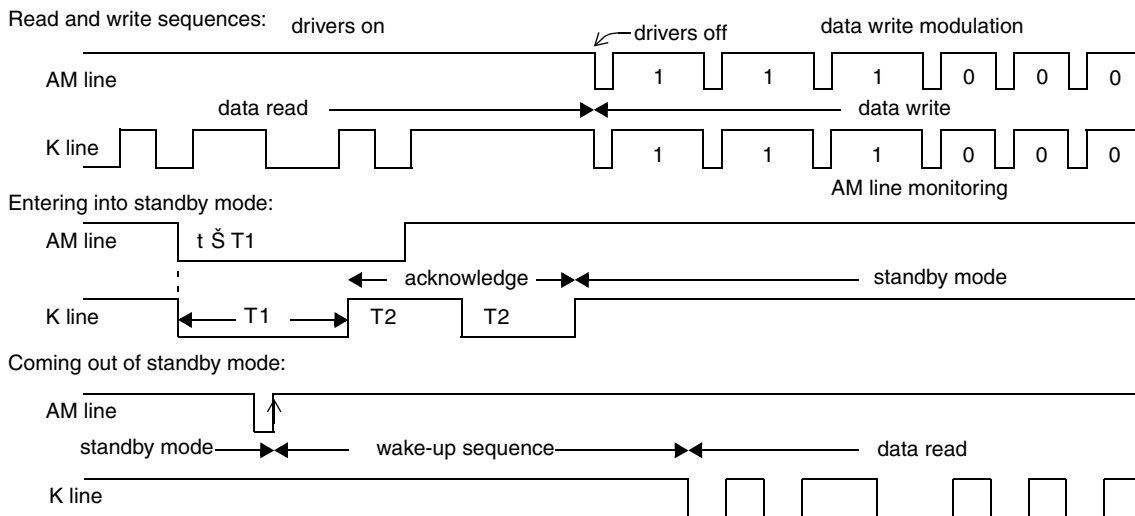

Figure 8. Modes Access Description in Two-wire Bus Configuration

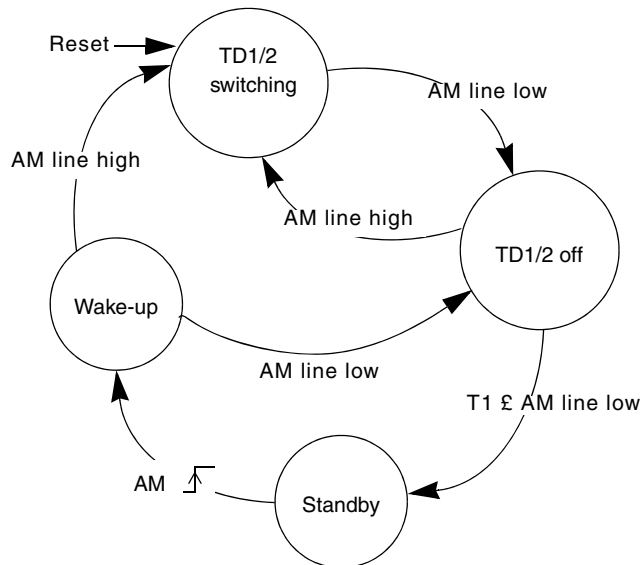

Figure 9. Configuration B State Diagram

9 Direct Connection to a Microcontroller Configuration

When a high level is applied on MODE1, the circuit is in configuration C (see Figure 26). The demodulated data are sent through DOUT.

The AM pin is set as a VDD referenced input pin receiving the AM command. Forcing high and low levels on AM achieves the amplitude modulation by switching on/off both antenna drivers. Meanwhile, this amplitude modulation can be monitored on DOUT. This allows antenna short and open circuit diagnosis.

The circuit can be put into standby mode by applying a low level on the MODE2 pin. In standby mode, the oscillator and most of the internal biasing currents are switched off. Therefore, the functions (tag reader and ISO 9141 interface) are inactive except for the voltage regulator. The driver outputs TD1 and TD2 are frozen in their state (high or low level) before entering into standby mode. DOUT forces a low level.

The ISO 9141 interface K is standalone and can be directly controlled by the input pin Tx and monitored by the output Rx. Applying a logic high level on Tx switches the output driver K on (dominant zero state when an external pull-up resistor is connected between K and VBAT). Applying a logic low level turns the driver off (one recessive state).

Rx monitors the voltage at the K pin. When the voltage is below the low threshold voltage, Rx forces a logic low level. When the voltage is above the high threshold voltage, Rx forces a logic high level.

In standby mode, Tx is disabled and Rx output monitors the voltage at the K pin.

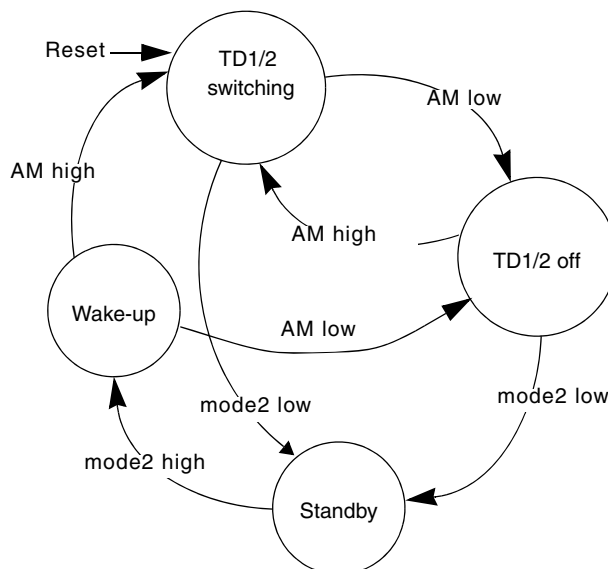

Figure 10. Configuration C State Diagram

10 Electrical Characteristics

Typical values reflect average measurements at $V_{SUP}=12V$ and $T_J=25^{\circ}C$.

11 Supply Current

Typical values reflect average measurements at $6V \leq V_{SUP} \leq 16V$, $V_{SS} = 0V$, $T_J = -40^{\circ}C$ to $+125^{\circ}C$, unless otherwise noted.

Table 5. Supply Current Specifications

Parameter	Symbol	Test Conditions and Comments	Min	Typ	Max	Unit	Type	
Pin VSUP								
9.1	Standby mode current	I_{SUP1}	—	300	500	μA	—	
9.2	Operating mode current	I_{SUP2}	Circuit in configuration C No current sunk from VDD Drivers TD1/2 switched off Tx forced to low	—	1.5	2.5	mA	—

12 Voltage Regulator

Typical values reflect average measurements at $6\text{V} \leq V_{SUP} \leq 16\text{V}$, $V_{SS} = 0\text{V}$, $T_J = -40^\circ\text{C}$ to $+125^\circ\text{C}$, unless otherwise noted

Table 6. Voltage Regulator Specifications

Parameter	Symbol	Test Conditions and Comments	Min	Typ	Max	Unit	Type	
Pins VSUP and VDD								
1.1	Output Voltage ($5.5\text{V} \leq V_{SUP} \leq 40\text{V}$)	V_{VDD1}	Without external MOS transistor, $I_{OUT} \leq 50\text{mA}$	4.75	5.0	5.25	V	—
1.3	Total Output Current	I_{VDD1}		—	—	50	mA	—
1.5	Load Regulation	$V_{LoadReg1}$	Without external MOS transistor, 1 to 50mA I_{OUT} change	—	20	60	mV	—
1.9	Output Voltage ($5.5\text{V} \leq V_{SUP} \leq 40\text{V}$)	V_{VDD2}	With external MOS transistor, $I_{OUT} \leq 150\text{mA}$ The stability is ensured with a decoupling capacitor between VDD and VSS: $C_{OUT} \geq 10\mu\text{F}$ with $\text{ESR} \leq 3\Omega$. The current capability can be increased up to 150mA by using an external N channel MOS transistor (see Figure 1). The main characteristics for choosing this component are $V_T < 1.8\text{V}$ and $\text{BVDSS} > 40\text{V}$.	4.7	5.0	5.3	V	—
1.11	Total Output Current	I_{VDD2}		—	—	150	mA	—
1.6	Load Regulation	$V_{LoadReg2}$	With external MOS transistor, 1 to 150mA I_{OUT} change	—	65	150	mV	—
1.4	Line Regulation ($6\text{V} \leq V_{SUP} \leq 16\text{V}$)	$V_{LineReg}$	$I_{OUT} = 1\text{mA}$	—	—	—	mV	—

13 Low-Voltage Reset

Typical values reflect average measurements at $6\text{V} \leq V_{SUP} \leq 16\text{V}$, $V_{SS} = 0\text{V}$, $T_J = -40^\circ\text{C}$ to $+125^\circ\text{C}$, unless otherwise noted

Table 7. Low-Voltage Reset Specifications

Parameter	Symbol	Test Conditions and Comments	Min	Typ	Max	Unit	Type		
Pin LVR									
1.6	Low Voltage Reset Low Threshold	V_{LVRON}	4.1	4.35	4.6	V	—		
1.7	Low Voltage Reset Hysteresis	V_{LVRH}	50	100	150	mV	—		
Because the voltage regulator and the low-voltage reset are using the same internal voltage reference, the low-voltage reset occurs only when the voltage regulator is out of regulation. See Figure 11									
1.12	Pull-up Current	I_{LVRUP}	$V_{LVR} = 2.5V$		5	10	15	μA	—
1.13	Output Resistance in reset condition	R_{LVR}	$V_{LVR} = 2.5V$		200	370	500	Ω	—
1.14	Input Low Voltage	V_{ILLVR}	—		0	—	$0.3 \times V_{DD}$	V	—
1.15	Input High Voltage	V_{IHLVR}	—		$0.7 \times V_{DD}$	—	V_{DD}	V	—

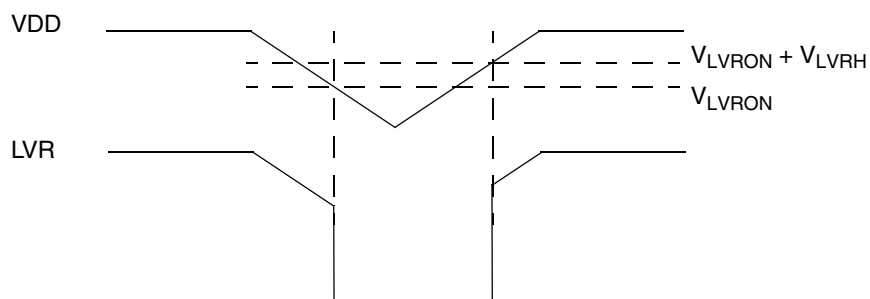

Figure 11. Low Voltage Reset Waveform

14 Oscillator

Typical values reflect average measurements at $6V \leq V_{SUP} \leq 16V$, $V_{SS} = 0V$, $T_J = -40^\circ C$ to $+125^\circ C$, unless otherwise noted

Table 8. Oscillator Specifications

Characteristic	Symbol	Test Condition and Comments	Min	Typ	Max	Unit	Type		
Pins XTAL1, XTAL2									
8.0	Input Capacitance	C_{XTAL1}	$V_{XTAL1} = 2.5V$		—	5	—	pF	—
8.1	Voltage gain V_{XTAL2} / V_{XTAL1}	A_{OSC}	$V_{XTAL1} = 2.5V$		—	25	—	—	—
8.3	Clock input level	V_{XTAL1}	This level ensures the circuit operation with an 8 MHz clock. It is applied through a capacitive coupling. A $1M\Omega$ resistor connected between XTAL1 and XTAL2 biases the oscillator input.		1.5	—	V_{DD}	Vpp	—

15 Tag Reader

Typical values reflect average measurements at $6V \leq V_{SUP} \leq 16V$, $V_{SS} = 0V$, $T_J = -40^\circ C$ to $+125^\circ C$, unless otherwise noted

Table 9. Tag Reader Specifications

Parameter	Symbol	Test Conditions and Comments	Min	Typ	Max	Unit	Type	
Demodulator (pin RD)								
2.0	Input Voltage Range	V_{INRD}	—	3	4	5	V	—
2.2	Input Modulation Frequency	F_{MOD}	—	0.5	4	8	kHz	—
2.3	Demodulator Sensitivity	V_{SENSE1}	$6.5V \leq V_{SUP} \leq 16V$ Sensitivity is measured in the following application conditions: $I_{ANTENNA} = 50mA$ peak, $V_{RD} = 4V$ peak, $C_{EXT} = 10nF$, and square wave modulation $F_{MOD} = F_{TD1}/32$. See Figure 12	—	5	15	mV	—
2.31	Demodulator Sensitivity	V_{SENSE2}	$6V \leq V_{SUP} < 6.5V$ The sensitivity is measured in the following application conditions: $I_{ANTENNA} = 50mA$ peak, $V_{RD} = 4V$ peak, $C_{EXT} = 10nF$, and square wave modulation $F_{MOD} = F_{TD1}/32$ See Figure 12	—	7	30	mV	—
2.4	Demodulation Delay	t_{Demod}	Configuration C Not including the delay due to the slew rate of the K output for configurations A and B See figure 12	—	7.5	10	μs	—
2.5	After Write Pulse Settling Time	$t_{Settling1}$	—	—	394	400	μs	—
2.6	Recovery Time after wake-up or reset from clock stable to demodulator valid output	$t_{Settling2}$	Clock stable condition implies V_{XTAL1} meets the specification (see page 15).	—	646	700	μs	—
Drivers (pins TD1, TD2)								
3.5	Output Carrier Frequency to Crystal Frequency Ratio	$R_{FTD/FXTAL}$	—	—	64	—	—	—
3.0	Turn on/off Delay	$t_{on/off}$	—	—	—	250	ns	—
3.1	Driver1/2 Low Side Out. Resistance	R_{TDL}	$I_{LOAD} = 150mA$ DC	—	2.4	4	Ω	—
3.2	Driver1/2 High Side Out. Resistance	R_{TDH}	$I_{LOAD} = -150mA$ DC	—	2.1	4	Ω	—

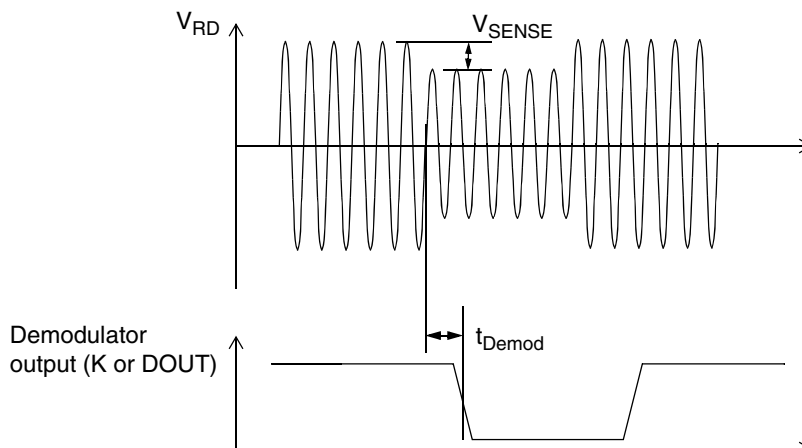

Figure 12. Demodulator Parameters Definition

16 ISO 9141 Interface

Typical values reflect average measurements at $6V \leq V_{SUP} \leq 16V$, $V_{SS} = 0V$, $T_J = -40^\circ C$ to $+125^\circ C$, unless otherwise noted

Table 10. ISO 9141 Interface Specifications

Parameter	Symbol	Test Conditions and Comments	Min	Typ	Max	Unit	Type		
Receiver (pins K and AM)									
4.0	Input Low Voltage	V_{IL}	—	—	$0.3 \times V_{SUP}$	V	—		
4.1	Input High Voltage	V_{IH}	$0.65 \times V_{SUP}$	—	40	V	—		
4.2	Input Hysteresis Voltage	V_{HY1}	0.4	0.65	1.3	V	—		
4.3	Biasing Current	I_B	$0V \leq V_{IN} \leq 16V$		1	3	5	μA	—
4.31	Input Current	I_{BM}	$-3V \leq V_{IN} < 0V$		-2	-1	—	mA	—
4.4	K to Rx delay	tdkrx	—	2	10	μs	—		
Driver (pin K)									
5.0	Output Falling Edge Slew Rate	SR_F	$R_{PULL-up} = 510\Omega$, Calculated from 20% to 80% of the output swing.	3.5	5	6.5	$V/\mu s$	—	
5.1	Output Rising Edge Slew Rate	SR_R		3.5	5	6.5	$V/\mu s$	—	
5.2	Rise Fall Slew Rates Symmetry	$SR_{SYMMETRY}$		-1	0	1	$V/\mu s$	—	
5.3	Output Low Voltage	V_{OLK}	$I_{LOAD} = 25mA$		—	1.1	1.4	V	—
5.4	Input Current (driver switched on or off)	I_{IK}	$-3V \leq V_{IN} \leq 0V$		-2	—	0	mA	—
5.5	Current Limitation Threshold	I_L	$0V \leq V_{IN} \leq 40V$		35	50	65	mA	—
5.6	Thermal Shutdown Threshold	TH_{SDWN}	—	130	150	170	$^\circ C$	—	

17 Digital I/O

Typical values reflect average measurements at $6V \leq V_{SUP} \leq 16V$, $V_{SS} = 0V$, $T_J = -40^\circ C$ to $+125^\circ C$, unless otherwise noted

Table 11. Digital I/O Specifications

	Characteristic	Symbol	Test Condition and Comments	Min	Typ	Max	Unit	Type
Input (pins MODE1, MODE2, AM, TX)								
6.0	Input Low Voltage	V_{ILD}	—	0	—	$0.3 \times V_{DD}$	V	—
6.1	Input High Voltage	V_{IHD}	—	$0.7 \times V_{DD}$	—	V_{DD}	V	—
6.2	Input Hysteresis Voltage	V_{HD}	—	.24	.7	1	V	—
Output (pins DOUT,RX)								
7.0	Output Low Voltage	V_{OL}	$I_{LOAD} = 500\mu A$	0	0.5	$0.2 \times V_{DD}$	V	—
7.1	Output High Voltage	V_{OH}	$I_{LOAD} = -500\mu A$	$0.8 \times V_{DD}$	4.6	V_{DD}	V	—
7.2	Fall/Rise Time	$t_{F/R}$	$C_{LOAD} = 10pF$, Calculated from 10% to 90% of the output swing	—	—	150	ns	—

18 Pin Definition and Function

The internal circuits connected to the pins of the device are shown in Figures 13 – 23, including the diodes used for ESD protection.

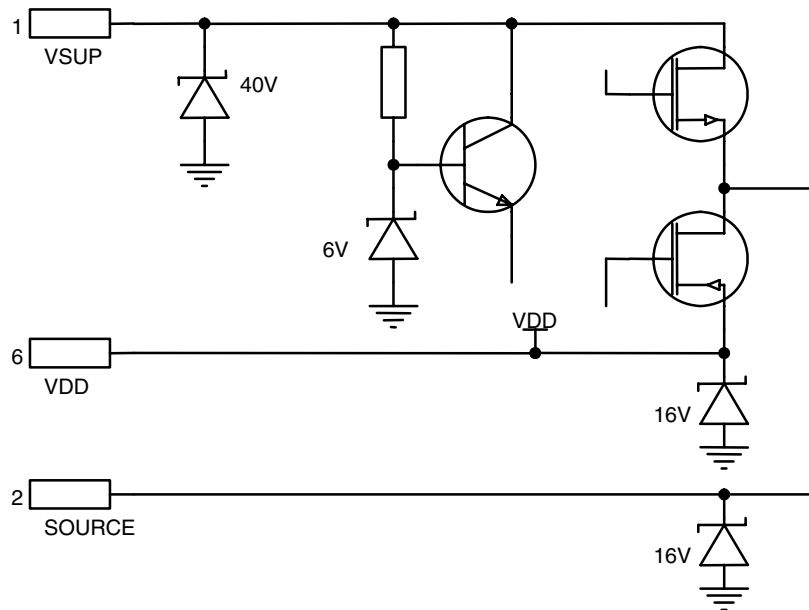

Figure 13. VSUP, VDD, and Source Internal Circuits

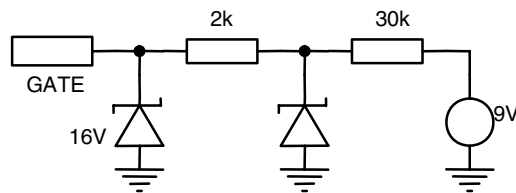

Figure 14. GATE Internal Circuits

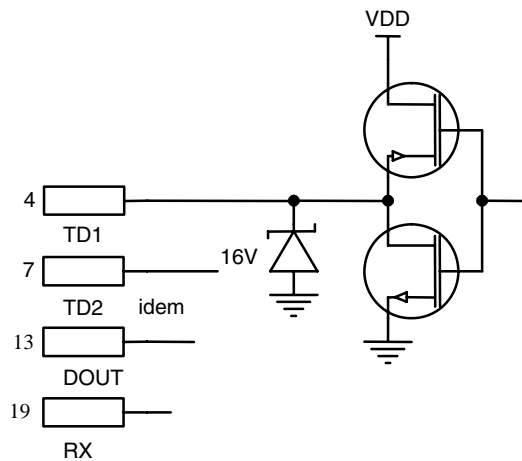

Figure 15. TD1, TD2, DOUT, and RX Internal Circuits

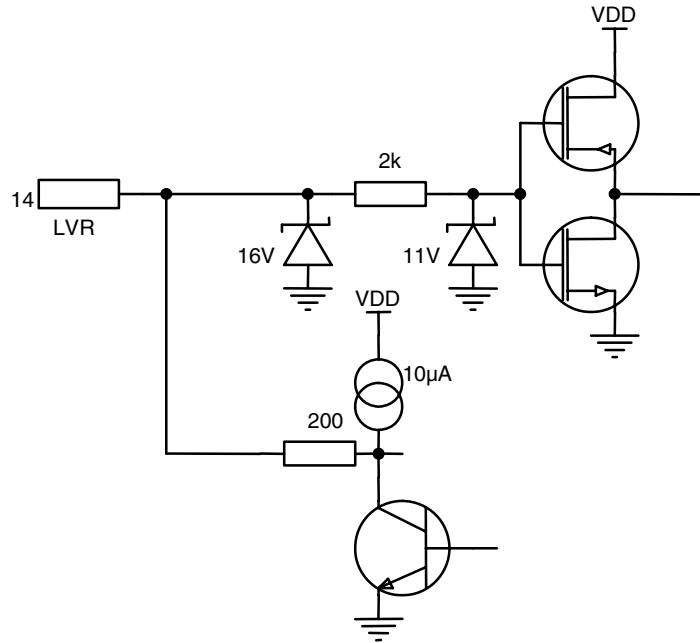

Figure 20. LVR Internal Circuits

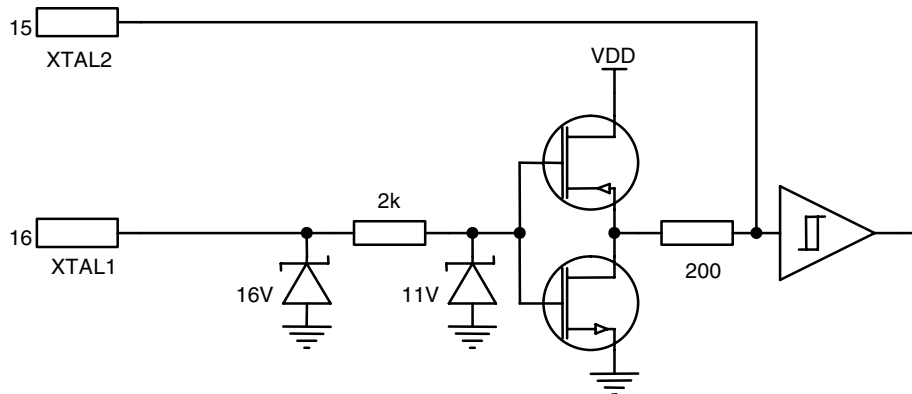

Figure 21. XTAL2 and XTAL1 Internal Circuits

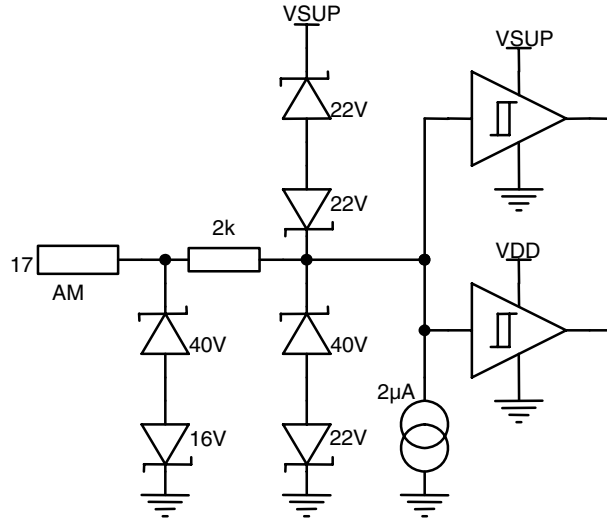

Figure 22. AM Internal Circuits

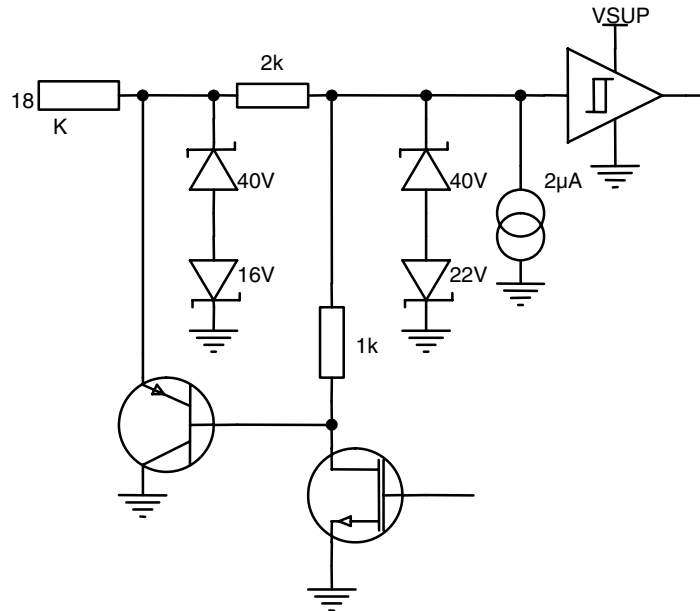
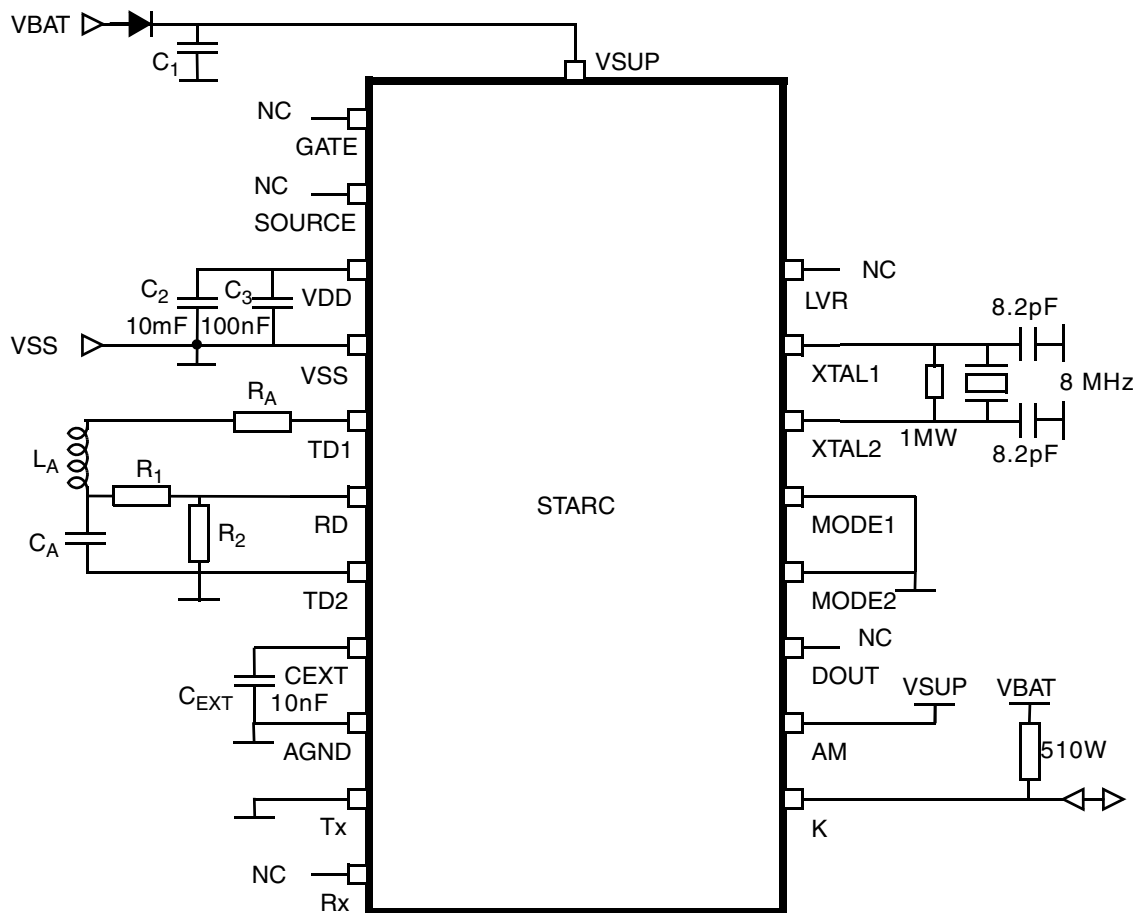

Figure 23. K Internal Circuits

19 Application Schemes



Note: If no external MOS transistor is necessary to increase the voltage regulator current capability, the pins GATE and SOURCE must be left unconnected. In this configuration, the outputs Rx and DOUT force a low level. C1 is not required for the STARC functionality and only acts as a reservoir of energy. To preserve the demodulator sensitivity, CEXT and R2 should be connected to AGND and VSS connected to AGND using a low resistance path.

Figure 24. Standalone Configuration with One-Wire Bus

Application Schemes

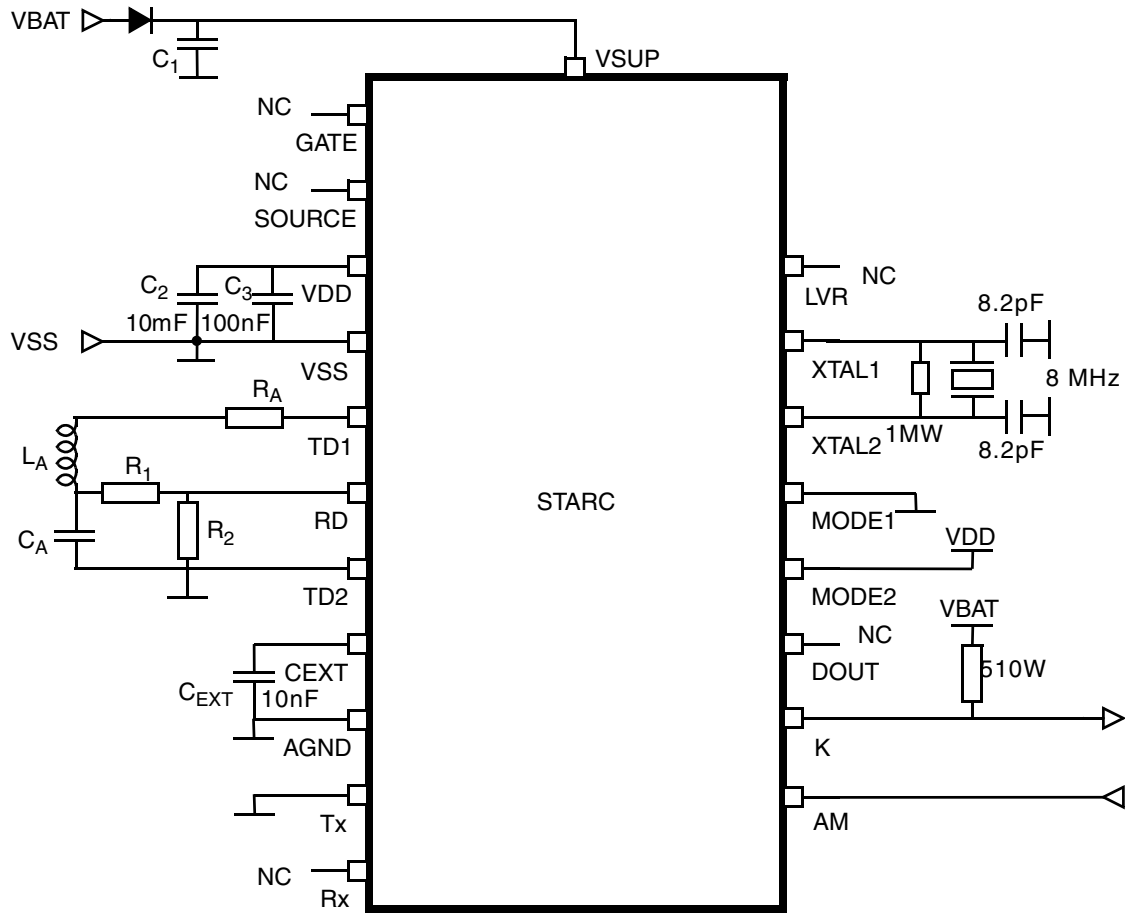

Note: If no external MOS transistor is necessary to increase the voltage regulator current capability, the pins GATE and SOURCE must be left unconnected. C_1 is not required for the STARC functionality and only acts as a reservoir of energy. To preserve the demodulator sensitivity, C_{EXT} and R_2 should be connected to AGND and VSS connected to AGND using a low resistance path.

Figure 25. Standalone Configuration with Two-Wires Bus

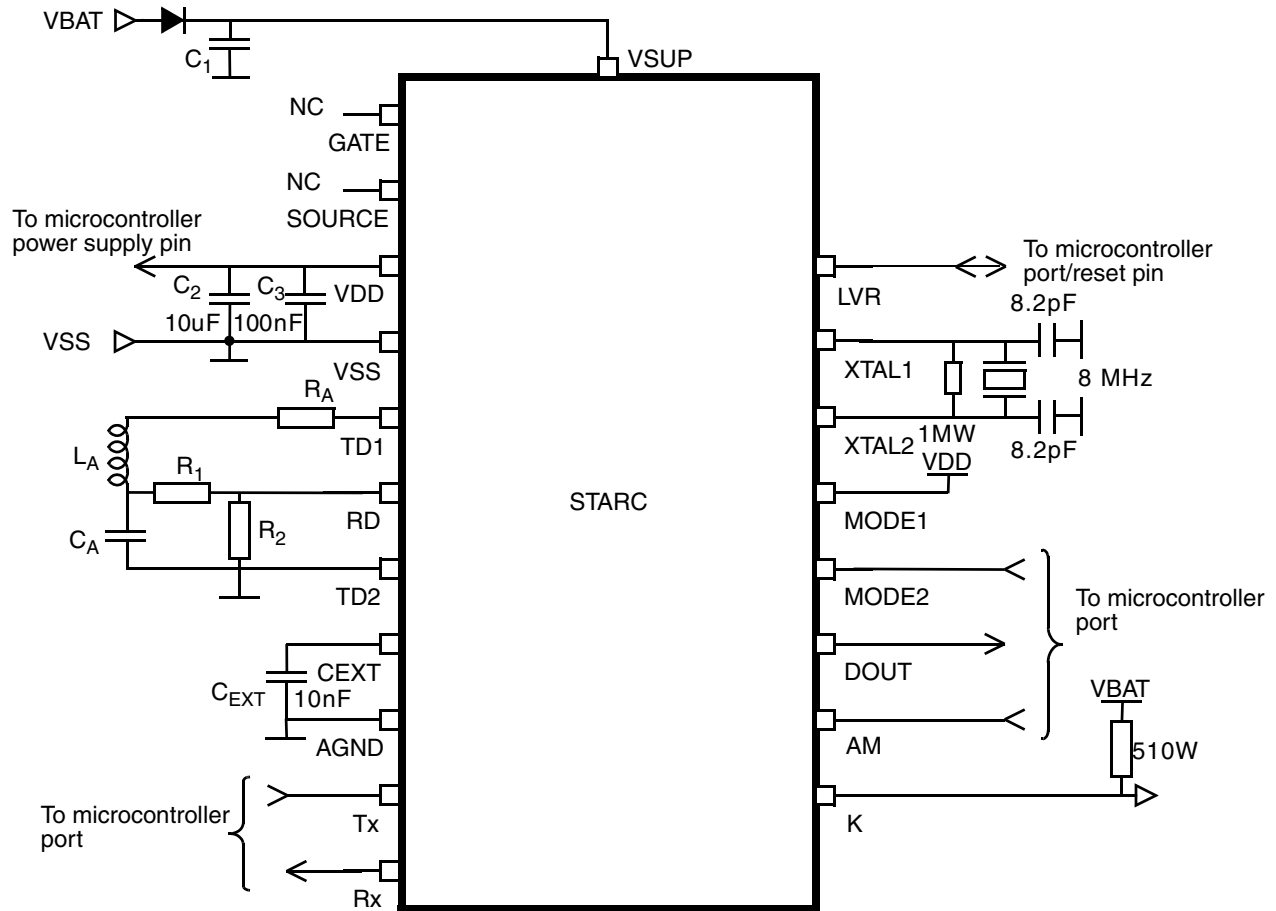

Note: If no external MOS transistor is necessary to increase the voltage regulator current capability, the pins GATE and SOURCE must be left unconnected. C_1 is not required for the STARC functionality and only acts as a reservoir of energy. To preserve the demodulator sensitivity, C_{EXT} and R_2 should be connected to AGND and VSS connected to AGND using a low resistance path.

Figure 26. Direct Connection to a Microcontroller

How to Reach Us:

Home Page:

www.freescale.com

Web Support:

<http://www.freescale.com/support>

USA/Europe or Locations Not Listed:

Freescale Semiconductor, Inc.
Technical Information Center, EL516
2100 East Elliot Road
Tempe, Arizona 85284
+1-800-521-6274 or +1-480-768-2130
www.freescale.com/support

Europe, Middle East, and Africa:

Freescale Halbleiter Deutschland GmbH
Technical Information Center
Schatzbogen 7
81829 Muenchen, Germany
+44 1296 380 456 (English)
+46 8 52200080 (English)
+49 89 92103 559 (German)
+33 1 69 35 48 48 (French)
www.freescale.com/support

Japan:

Freescale Semiconductor Japan Ltd.
Headquarters
ARCO Tower 15F
1-8-1, Shimo-Meguro, Meguro-ku,
Tokyo 153-0064
Japan
0120 191014 or +81 3 5437 9125
support.japan@freescale.com

Asia/Pacific:

Freescale Semiconductor Hong Kong Ltd.
Technical Information Center
2 Dai King Street
Tai Po Industrial Estate
Tai Po, N.T., Hong Kong
+800 2666 8080
support.asia@freescale.com

For Literature Requests Only:

Freescale Semiconductor Literature Distribution Center
P.O. Box 5405
Denver, Colorado 80217
1-800-441-2447 or 303-675-2140
Fax: 303-675-2150
LDCForFreescaleSemiconductor@hibbertgroup.com

Document Number: SC33690DS

Rev. 5

02/2007

Information in this document is provided solely to enable system and software implementers to use Freescale Semiconductor products. There are no express or implied copyright licenses granted hereunder to design or fabricate any integrated circuits or integrated circuits based on the information in this document.

Freescale Semiconductor reserves the right to make changes without further notice to any products herein. Freescale Semiconductor makes no warranty, representation or guarantee regarding the suitability of its products for any particular purpose, nor does Freescale Semiconductor assume any liability arising out of the application or use of any product or circuit, and specifically disclaims any and all liability, including without limitation consequential or incidental damages. "Typical" parameters that may be provided in Freescale Semiconductor data sheets and/or specifications can and do vary in different applications and actual performance may vary over time. All operating parameters, including "Typicals", must be validated for each customer application by customer's technical experts. Freescale Semiconductor does not convey any license under its patent rights nor the rights of others. Freescale Semiconductor products are not designed, intended, or authorized for use as components in systems intended for surgical implant into the body, or other applications intended to support or sustain life, or for any other application in which the failure of the Freescale Semiconductor product could create a situation where personal injury or death may occur. Should Buyer purchase or use Freescale Semiconductor products for any such unintended or unauthorized application, Buyer shall indemnify and hold Freescale Semiconductor and its officers, employees, subsidiaries, affiliates, and distributors harmless against all claims, costs, damages, and expenses, and reasonable attorney fees arising out of, directly or indirectly, any claim of personal injury or death associated with such unintended or unauthorized use, even if such claim alleges that Freescale Semiconductor was negligent regarding the design or manufacture of the part.

RoHS-compliant and/or Pb-free versions of Freescale products have the functionality and electrical characteristics as their non-RoHS-compliant and/or non-Pb-free counterparts. For further information, see <http://www.freescale.com> or contact your Freescale sales representative.

For information on Freescale's Environmental Products program, go to <http://www.freescale.com/epp>.

Freescale™ and the Freescale logo are trademarks of Freescale Semiconductor, Inc. All other product or service names are the property of their respective owners. The Power Architecture and Power.org word marks and the Power and Power.org logos and related marks are trademarks and service marks licensed by Power.org
© Freescale Semiconductor, Inc. 2007. All rights reserved.

